

RESEARCH

BIS | Department for Business
Innovation & Skills

BIS RESEARCH PAPER NUMBER 62

Tracking International Graduate
Outcomes 2011

JANUARY 2012

The International Graduate Insight Group Ltd.

(i-graduate)

Will Archer and Jacqueline Cheng

E-mail: jacqueline.cheng@i-graduate.org

Telephone: +44 (0) 1737 772 250

Website: www.i-graduate.org



The views expressed in this report are the authors' and do not necessarily reflect those of the Department for Business, Innovation and Skills.

Department for Business, Innovation and Skills

1 Victoria Street

London SW1H 0ET

www.bis.gov.uk

BIS Research Paper number 62

January 2012

Contents

Contents	3
1. Executive Summary	6
Circumstances and destinations of non-EU international graduates	6
Reflections on the experience of UK higher education	8
Feasibility of including international graduates in future DLHE waves.....	8
Concluding observation.....	9
2. Introduction	10
2.1 Context.....	10
3. Methodology.....	12
3.1 Procedure.....	12
Phase One (2009): Literature Review	12
Phase Two (2009, 2010): Consultation.....	12
Phase Three: Primary research with non-EU graduates (2010 and 2011)	12
3.2 Feedback from the first wave	13
3.3 Participation and response.....	14
3.4 The questionnaire	16
4. Results	18
4.1 Sample demographics	18
4.2 Employment	22
Employment circumstances	25
Organisation type and size.....	31
Job specifications and type	33
Salary	43

The International Education Premium – employment in UK	45
The UK education premium – employment in home country	46
The ‘Global Graduate’ Premium – working in a third country.....	46
Perceptions and motivations	51
4.3 Further study	56
Study circumstances	56
Qualifications.....	60
Place of further study, training or research	62
Further study motivations.....	62
4.4 Visas and time in UK.....	63
Visa application	63
Visa type	64
Visa satisfaction	69
Plans to stay in the UK.....	70
4.5 Reflections of the UK experience.....	72
Employment in the UK during or before course	72
Motivations to study in the UK.....	75
Overall reflections	76
Financial Investment	79
Career Progression and Commanding a Higher Salary.....	84
Commanding a higher salary	84
Learning Experience	85
Living Experience.....	86
Support from University.....	86

UK Welcome	87
4.6 Future plans	87
4.7 Recommendation	93
Recommending the specific institution	93
Recommending the UK	95
5. Conclusions	96
6. Recommendations	97
Appendix 1 – Steering Group Members.....	99
Appendix 2 – List of participating institutions in 2011.....	100
Appendix 3 – Comparison of i-GO sample and HESA population	102
Appendix 4 –DLHE survey (courtesy of HESA)	103
Appendix 5 – i-GO questionnaire	105
Appendix 6 – Employment status as defined by HESA*	95
Appendix 7 –Status of graduates, 6 months after graduation, by study level (2010 cohort).....	96
Appendix 8 –Status of graduates, 2½ years after graduation, by study level (2008 cohort).....	97
Appendix 9 – Status of graduates, 6 months after graduation, by study level (2009 cohort).....	98
Appendix 10 – Status of graduates, 2½ years after graduation, by study level (2007 cohort).....	99
Appendix 11 –Status of graduates, 6 months after graduation, by top 3 nationalities (2010 cohort)	100
Appendix 12 – Status of graduates, 2½ years after graduation, by top 3 nationalities (2008 cohort)	101

1. Executive Summary

The International Graduate Insight Group (i-graduate) was commissioned to run a study of International Graduate Outcomes (i-GO)¹ by the Department for Business, Innovation and Skills (BIS) in November 2009.

The first wave of the study took place in 2010 and surveyed international graduates (those who graduated from undergraduate, taught and research postgraduate degrees) of publicly-funded UK higher education institutions (HEIs) from 2009 (6 months after completing their studies) and from 2007 (in the third year post-completion). The second and final wave, conducted in 2011, surveyed international graduates who had graduated from UK HEIs in 2010 (6 months after completion) and 2008 (2½ years after completion).

The aims of the study are:

- 1) To establish the **circumstances and destinations** of non-EU international graduates after they leave UK higher education, comparing those who graduated six months ago to those who graduated two and a half years ago;
- 2) Examining the **reflections of international graduates** regarding their UK study;
- 3) Assessing the **feasibility of including international graduates** in future Destinations of Leavers from Higher Education (DLHE) surveys.

The total number of graduates responding to the 2011 survey was 7,620 (2,113 from 2008 cohort, and 5,507 from 2010 cohort) from 63 participating institutions. There were 5,708 responses from the first wave.

Circumstances and destinations of non-EU international graduates

For 2010 international graduates, six months after graduation, 86% are in employment or further study. In their third year after graduation, 95% of the class of 2008 are employed or studying

¹ After the first phase ended in September 2010, it was recommended that the study be renamed the "International Graduate Outcomes"

study (i-GO) as the study is not in fact, tracking international students, so the original name of International Student Tracking Study was misleading.

- These figures are comparable to the first wave of this research (in 2010) which found that 78% of new graduates were working or studying, rising to 95% in the third year post-graduation.
- Six months after graduation, for those in employment, 85% of graduates are in graduate-level jobs. The figure increases marginally to 87% in the third year post-graduation.
- In the first year after graduation of those who are working, 22% are in the UK. Three years after graduation, 17% of those who are working are in the UK.

UK-educated international graduates achieve markedly higher average salaries than in their home country.

- There is a diverse range of salaries in the different home countries of graduates. The average starting salary for recently graduated international alumni returning to their home country to work is £18,406. For graduates in their third year out, this figure is higher, at £20,574.
- Recent graduates returning to China to work, achieve an average starting salary of £9,675. Those returning to India, achieve an average starting salary of £13,214. US graduates return home to an average starting salary of £28,055. These compare to average starting salaries in China, India, and the USA of £4,152, £4,394, and £24,514 respectively.
- The average starting salary for recent international (non-EU) graduates working in the UK is £23,960. The average for 2008 graduates in their third year post graduation is understandably higher at £30,029 due to career progression.
- Of the class of 2010 who are in employment, 10% are working outside the UK and not in their home country. This most-mobile group achieve the highest average starting salary of £33,626.
- Average salaries for 2010 non-EU graduates with a bachelor's degree are £18,278, for taught postgrads £20,443 and for PGR graduates £31,660.

18% of recent graduates are engaged in further study solely, and 14% are engaged in further study and employment concurrently.

- Of the 18% who are in further study only, 64% are in the UK and 27% have returned home.
- For those in their 3rd year post-graduation, 7% are engaged in further study solely, and 21% in further study with employment.

Reflections on the experience of UK higher education

Satisfaction is high across all learning, living, and support aspects of the HEI experience for all graduates

- 83% of the class of 2010 and 85% of the class of 2008 would recommend their institution to others.
- 88% of 2010 graduates and 91% of 2008 graduates are satisfied with the learning experience
- Overall, 88% of graduates are satisfied, from both 2010 and 2008, with the living experience.
- 82% of graduates are satisfied, from both 2010 and 2008, with the support provided by their university overall.
- Three years after graduating, 83% felt that their UK degree was worth the financial investment as do 80% of those who graduated 6 months ago.
- In addition, 86% of 2010 graduates and 87% of 2008 graduates reported feeling welcome in the UK when they first arrived.
- On reflection of the visa application process, 78% of those graduating 6 months ago were satisfied, as were 77% of those who graduated 3 years ago, regardless of the outcome of the process.
- Career progression was the major factor in course selection for all cohorts.
- 86% of both cohorts seek to remain connected to their university.

Feasibility of including international graduates in future DLHE waves

- Decision made – international graduates will feature from 2012, in the DLHE reporting process. However, no minimum response level has been set. After two years, an assessment will be made to inform a decision on an appropriate target response rate.
- There is no doubt that international graduates, prospective students, governments and funding bodies will increasingly judge the value of international education - and the comparative value of nations - on graduate outcomes.
- Quality of contact databases for international alumni is extremely variable. This has been the biggest hurdle for institutions participating in this study and is one of the strongest learning points: universities must ensure they hold up-to-date contact details for their graduates – especially since the majority of graduates are keen to keep in touch with their university.

Concluding observation

- There is no doubt that UK HE has a strong story to tell. Perceptions of the value of a UK education will be strengthened by the evidence collected in the course of this study. But perceptions are variable, evidently within any cohort and certainly across the years. It is vital for UK HE and UK PLC to maintain a substantive measure of international graduate outcomes, an objective indicator of international graduate destinations and a finger on the pulse of graduate opinion. In no small part, the reputation of higher education is now defined and redefined, year on year, by current students and by recent graduates, reflecting on the value of and outcomes from their UK study experience.

2. Introduction

The i-GO has benefited from a pilot study in 2010 that included a review of literature, three round table conferences, and an online consultation survey of representatives from publicly funded Higher Education Institutions (HEIs). In addition, this final report has been produced following consultation from a steering group coordinated by BIS and incorporated feedback from its members (see Appendix 1 for steering group member participation).

The main questions that are of interest are:

- 1) Where do international students go after graduating? How many stay in the UK, return home, or venture onto another country?
- 2) What do graduates typically do after leaving university? What are their career paths?
- 3) How did they find their experience in the UK whilst they were studying?
- 4) Would they recommend their institution and the UK as a study destination?

All of these questions are answered in depth, drawing out comparisons between different groups (e.g. age, gender, nationality, area and level of study). The focus will be on those who graduated in 2010, although the report will also highlight any important patterns through the years from students graduating in 2008.

2.1 Context

The UK has been through significant changes that have affected its higher education landscape. Funding cuts, immigration changes, and increased fees for domestic students, all contribute to the debate about whether the UK is an attractive place for international students to study and remain in the country to work after study.

Despite these changes, international students (non-EU) still represent a substantial element of the UK HE system, with 11% of the UK's total student population. 27% of the UK's postgraduate student population are from non-EU countries². As set out in the overview of the PMI2 by the British Council³, international education is not just an export industry: while international students represent a considerable amount of direct income to HEIs through fees and to the wider economy, the number of

² HESA 2009/10 Students in Higher Education Institutions:

http://www.ukcisa.org.uk/about/statistics_he.php#sources

³ <http://www.britishcouncil.org/eumd-pmi2-overview.htm>

international students in the UK also opens networks with people around the world and encourages greater trade, investment and research opportunities.

In 2002/2003, the Higher Education Statistics Agency (HESA)'s Destination of Leavers from Higher Education (DLHE) replaced the former First Destinations Supplement to collect richer information annually from UK and EU students about their activities after gaining a qualification from a UK higher education institution. The DLHE survey covers all those who completed their studies in publicly funded HEIs. In 2009/10, over 395,000 responses were collected from UK and EU leavers from all UK HEIs.

The DLHE process was designed to capture detailed information regarding the early career destinations of UK and EU graduates, although some HEIs also survey their non-EU international graduates. The Longitudinal DLHE is a follow-up sample survey which captures information from students who responded to the DLHE and who completed their studies 3 years previously. A longer questionnaire is used to capture more detail about the graduate's satisfaction with their university experience, employment, and further study/research circumstances. However, the destinations of non-EU leavers are not currently tracked nationally as earlier attempts to capture such information resulted in low returns and limited information. Plans are underway to include the non-EU international graduate population in future waves of DLHE beginning in the 2011/12 wave. In the consultation process about incorporating non-EU graduates, HEIs were mostly positive about this move whilst noting that they needed time to develop their systems for maintaining contact information. Resource implications for telephone or paper surveys would also be considerable. However, this information is crucial in building a more comprehensive picture about the contributions that international students bring to the UK, not only whilst studying, but after graduating as well.

3. Methodology

3.1 Procedure

The entire research process for the two-year project was split into three phases:

Phase One (2009): Literature Review

The first phase of the research was a desk review of existing literature relevant to outcomes of international students and graduates.

There was a limited quantity of information published relevant to non-EU graduate destinations within the UK. The search was extended to the USA and Australia, where a small amount of useful data relating to this area was located. This information was reported to BIS within the Literature Review documentation.

Phase Two (2009, 2010): Consultation

Consultation with publicly funded HEIs and stakeholders in the sector was conducted from November 2009 to February 2010. This phase included round table discussion groups and an online survey designed to gather feedback and input from representatives across the sector. At each round table, i-graduate endeavoured to obtain representation from institutions of different sizes and types, as well as inviting staff with a range of roles and responsibilities.

Responses were invited from UK HEI staff from careers services (including DLHE managers), international offices, alumni departments, marketing & market research offices, as well as senior institution managers including Registrars and Vice Chancellors. The consultation survey received feedback from 329 individuals from 133 HEIs across the UK HE sector.

In addition, i-graduate conducted five in-depth telephone interviews with careers service managers, including three DLHE managers, at institutions where regular non-EU graduate destinations survey activity is already established.

Full reporting on the consultation phase was delivered to BIS in March 2010.

Phase Three: Primary research with non-EU graduates (2010 and 2011)

Feedback from key stakeholders in Phase Two indicated that 6 months after completion of studies is too early to capture meaningful information – thus, data collection was extended to an additional cohort.

This research phase was carried out in 2010 and in 2011 and gathered information from 4 cohorts of graduates. In 2010, information was gathered on students who left in 2007 and 2009. In 2011, information was captured from graduates who completed studying in 2008 (approximately two and a half years out), in addition to graduates who finished UK studies in 2010 (approximately six months out).

Phase three was an online survey of non-EU graduates, all of whom were surveyed between 18th April and 23rd May 2011. This was the same time frame as 2010 to ensure comparability.

3.2 Feedback from the first wave

The steering group last year recommended further developments for the study this year. Amongst them, i-graduate:

- Changed the name of “International Student Tracking Study” to “International Graduate Outcomes”
- Extended the registration period to ensure the maximum numbers of institutions are able to participate. We went one step further and contacted non-participating institutions to see if they were willing to share their data collected from the DLHE process. Three institutions (University of Warwick, University of Cambridge, and the University of Oxford) shared their data which was then collated into the survey data. As a result, the total number of responses collected this year for the key questions is greater (7,620) than last year (5,708) despite fewer institutions taking part. Last year, 78 institutions took part whilst this year, only 63 launched the survey to their graduates.
- The i-GO questionnaire was reviewed to examine whether any questions should be removed or amended. All the DLHE core questions were kept in the questionnaire and in general, it was felt that any changes would limit the potential comparability of the data between the two studies. Thus, the questionnaire was kept the same.
- Email was kept as the only method of contacting graduates and emails were sent out by the relevant person in each institution. The use of telephone ‘boosting’ was suggested last year. As staff resources in each institution were already stretched, the telephone method would not have been practical to implement.

Recommendations were suggested for HEIs as well. The main ones included:

- Encouraging students to update their details before leaving the institution; collecting these email addresses when they visit the Careers office. Networking with alumni regularly to give them a reason to update their details as things change.

- Gathering graduate details from across the institution and centralising a graduate contact list, storing all known email addresses and telephone numbers. Regardless of which department holds the list, ensure that there is good cooperation between administrative departments.
- Keeping good records of rejected or bounced email addresses and updating contact lists accordingly.

However, from institutional feedback about participation issues, i-graduate felt that many HEIs still need to implement the above suggestions. The inclusion of non-EU international leavers in the future 2011/12 DLHE wave by HESA will hopefully highlight these recommendations and it will be a requirement for HEIs to survey them electronically. A target response rate will not be set for the first two implementations (2011/12 and 2012/13). There will be a review after two years in order to inform a decision on an appropriate target response rate. Non-EU international graduates will also be incorporated into the longitudinal DLHE process with the 2012/13 cohort of leavers being surveyed in 2016/17.

3.3 Participation and response

All institutions in the UK were contacted via email and telephone to invite them to participate in the 2011 i-GO. In addition, a letter was sent from BIS to the relevant careers or alumni heads to show support for the study and to encourage institutions to participate.

In the first wave in 2010, 85 UK HEIs registered to participate in the i-GO with 78 actually launching the survey to their alumni from one or both target years (2007 and 2009 graduates); 66 HEIs launched to both cohorts. Eight institutions launched only to 2007 graduates due to existing survey activity with more recent graduates, and four HEIs sent the survey only to 2009 graduates due to poor contact details for graduates from the earlier graduation point. Responses were collected from 5,708 non-EU international undergraduates and postgraduates who had completed their studies at a UK HEI - 3,419 in 2007 and 2,289 in 2009.

This year, 78 UK HEIs registered to participate with 63 launching the survey via email (see Appendix 2) to the target years (2008 and 2010 graduates). For HEIs that registered but did not launch the survey, reasons included staff resourcing and problems of gaining access to databases, or creating the contact list to launch the survey (see below section on “Issues affecting participation”). In terms of response rates, the sample gathered via the i-GO represents 2% of the entire UK international population for the 2010 cohort, and 1% for the 2008 cohort. From the comparison between the i-GO sample and the HESA (non-EU) population of HE students in the UK (Appendix 3), it appears that the i-GO sample is a good reflection of the international cohort of graduates from the UK in general. Response rates from

institutions varied from less than 1% to 11% based on the number of non-EU international students enrolled in the years 2008 and 2010.

i-graduate provided participating institutions with suggested email invitation text to be sent to the non-EU graduate cohorts. The email invitation text explained the purpose of the study and detailed how the data would be used, in addition to providing the institution specific hyperlink that directed email recipients to the online i-GO questionnaire hosted using i-graduate's survey software capability. Graduates from both cohorts were directed to the same survey, within which certain questions were visible or hidden depending on the year of completion of studies.

In the course of the discussions leading up to registration and participation, institutions fed back a number of issues that needed to be overcome in order for them to participate in the i-GO.

Duplication of existing survey activity, internal issues of administration, pressures on staffing and budgets and poor contact records for non-EU graduates were amongst other reasons that prevented institutions from participating and the specifics of each are listed in table 3.2. This anecdotal feedback provides information regarding the limitations of HEIs contacting non-EU international graduates via email.

The i-GO was conducted using an online-only method. Institutions were encouraged to send at least 2 reminders out to their graduates and offer incentives if possible. There was substantial variation in the response rates achieved across the individual institutions and in many cases the number of responses is too low to report at an institutional level. Indeed, part of the purpose of the study is to report the feasibility of assigning a target response rate for non-EU international graduates for DLHE.

Table 3.2 - Issues affecting participation

Main issue	Anecdotal feedback
Database of contact details of graduates	<ul style="list-style-type: none"> • No mechanism for collecting non-EU contact details; • No email addresses held for non-EU graduates; • Lack of resource for preparing the contact list(s) required for non-EU graduates; • Unable to identify non-EU graduates within institution's graduate contact database; • Concerns about the validity of non-EU graduate contact detail database.
Careers department resources	<ul style="list-style-type: none"> • No personnel available to manage i-GO survey or launch process; • Suitable resource already fully occupied managing DLHE; not possible to manage both processes in parallel on current resource levels.
Issues of authority and jurisdiction	<ul style="list-style-type: none"> • Non-EU graduate contact details not centrally managed: held by alumni department or occasionally by international office. • Dependent on co-operation of other departments and/or allocation of resource by other departments to obtain access to non-EU graduates and database extraction.
Concerns about questionnaire	<ul style="list-style-type: none"> • Institutions already running their own non-EU destinations survey were generally unable to participate in the i-GO for their 2009 cohort as the surveys would duplicate. Seven HEIs indicated that they are surveying international graduates through their DLHE⁴. • For others that did not already have their own survey, saw the i-GO as an opportunity to test their student records system for future DLHE waves.

3.4 The questionnaire

The i-GO (see Appendix 5 for the i-GO questionnaire) is intended to both parallel the core DLHE questions (see Appendix 4 for the DLHE questionnaire) and also extend the information collected to broader areas. In addition to collecting data regarding employment/study undertaken since completion of studies, the questionnaire also

⁴ However, University of Warwick, University of Oxford, and University of Cambridge offered their anonymised international graduates data for comparable questions in the i-GO which have been incorporated into the results here.

gathered data about current location (in the UK, graduate's home country, or elsewhere overseas), graduates' reflections of their time in UK higher education and their likelihood to recommend the UK to peers. Information was also captured about graduates' intentions regarding future relationships with the UK and views on aspects of the UK visa system.

4. Results

4.1 Sample demographics

In total, there were 7,620 responses to the survey. 2,113 respondents graduated in 2008 and the remaining 5,507 respondents graduated in 2010. The greater number of 2010 graduates is due to the incorporation of 2,502 records from the 2009/10 DLHE collection of international graduates from the three institutions specified previously. As the questions from the DLHE survey were identical to the questions in the i-GO survey, the answers could be directly imported.

Most respondents were aged between 22 to 30 years (71%; see figure 4.1.1), with the average age of 2008 cohort respondents being 28 years and the average age of 2010 cohort respondents being 25 years. The breakdown between UG, PGT, and PGR graduates in the 2010 sample was 26%, 48%, and 26% respectively, and 26%, 66%, and 8% respectively for the 2008 graduate sample (also see Appendix 3).

Figure 4.1.1 - 2008 and 2010 cohort age bands by study level

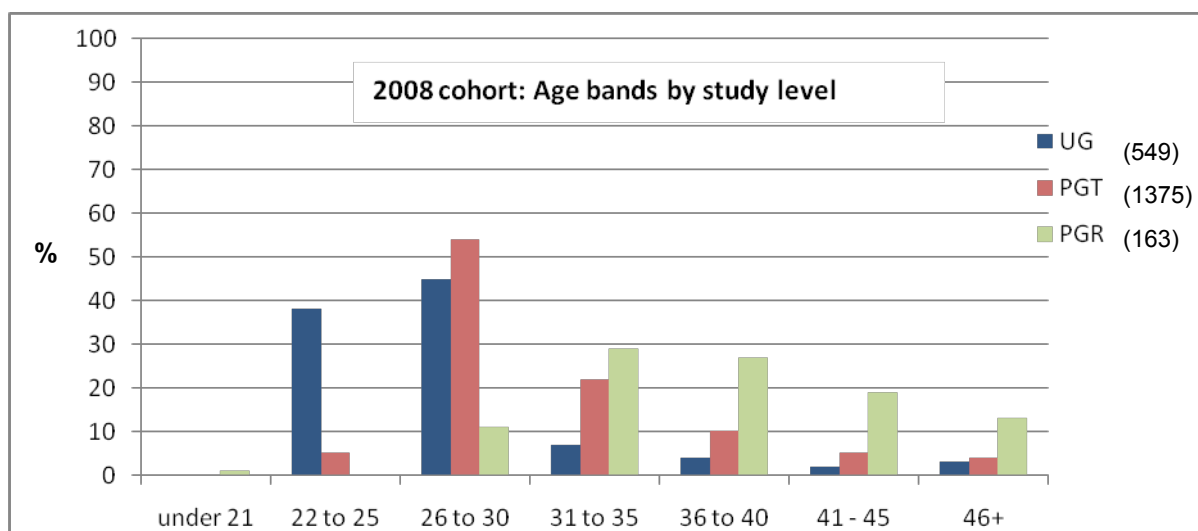

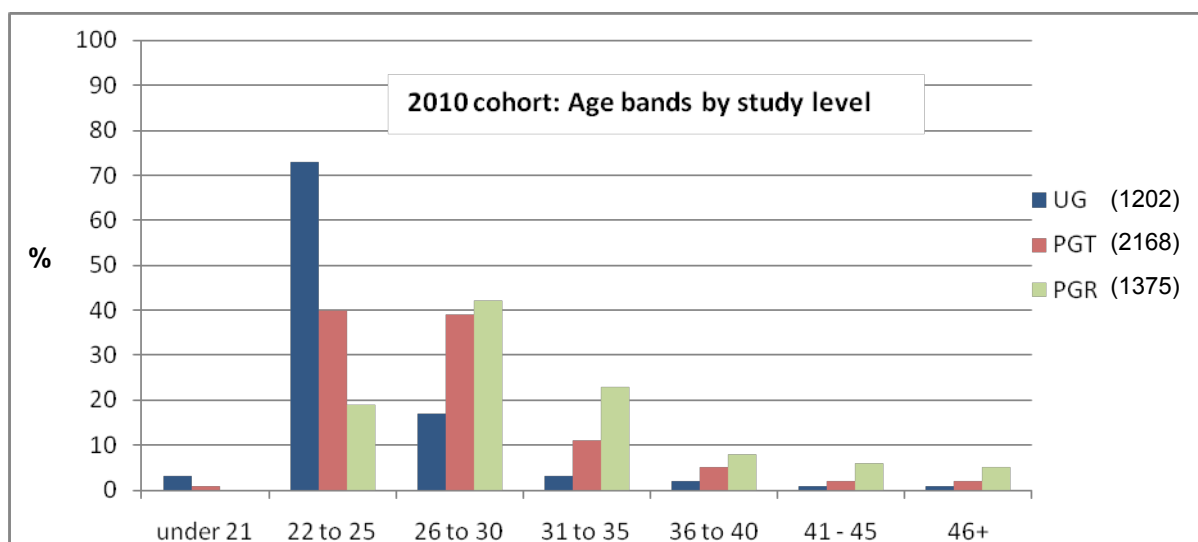

There were 149 nationalities in the total sample, with 140 represented in 2010 and 112 represented in 2008.

The top ten nationalities are presented here in figure 4.1.2, and they are:

- 1) Chinese
- 2) Indian
- 3) American
- 4) Malaysian
- 5) Nigerian
- 6) Canadian
- 7) Pakistani
- 8) Hong Kong Chinese
- 9) Taiwanese
- 10) Singaporean

Throughout the report, breakdowns of responses will be provided by these top ten nationalities (or top five nationalities if the base number of responses is low)

Figure 4.1.2 - 2008 and 2010 cohort: Area of Study by Study Level

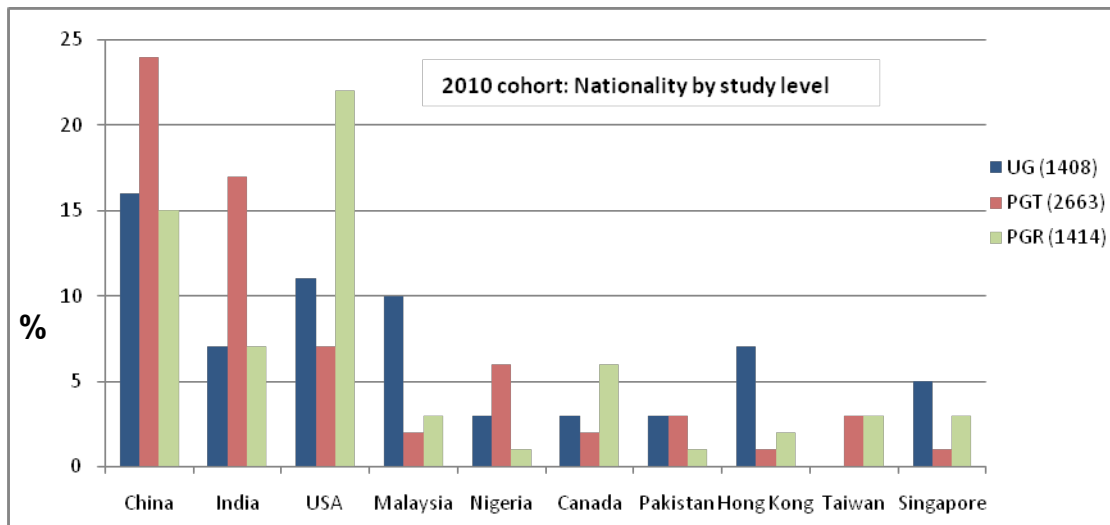
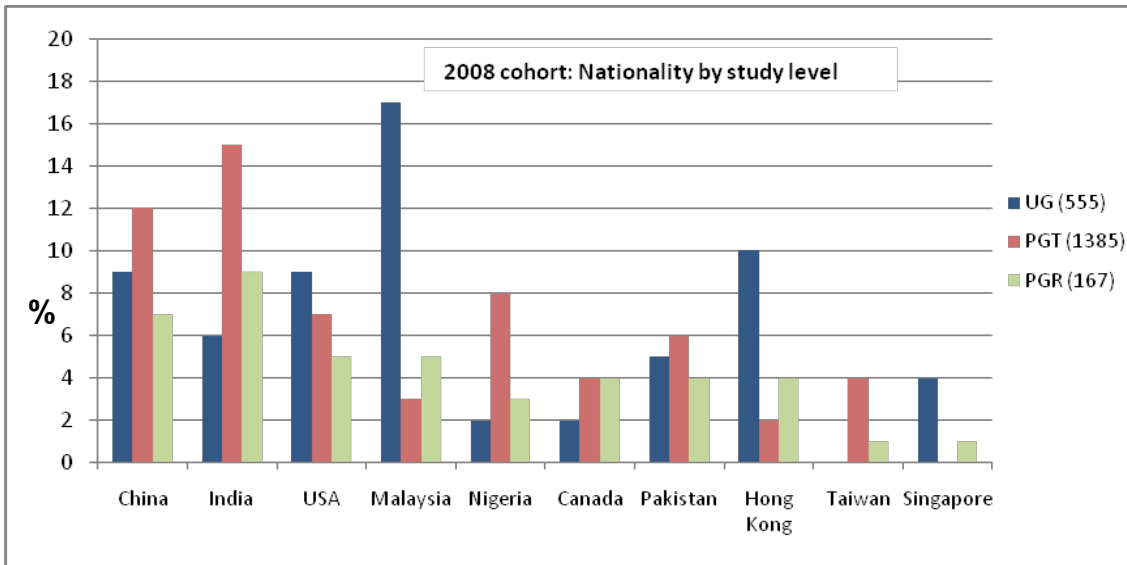

The most represented area of study amongst both the 2008 and 2010 cohorts of graduates is Business and administrative studies (25%), followed by Engineering (15%), and Social Studies (12%). The split by level of study is illustrated in figure 4.1.3.

Figure 4.1.3 - 2008 and 2010 cohort: top 10 areas of study by study level

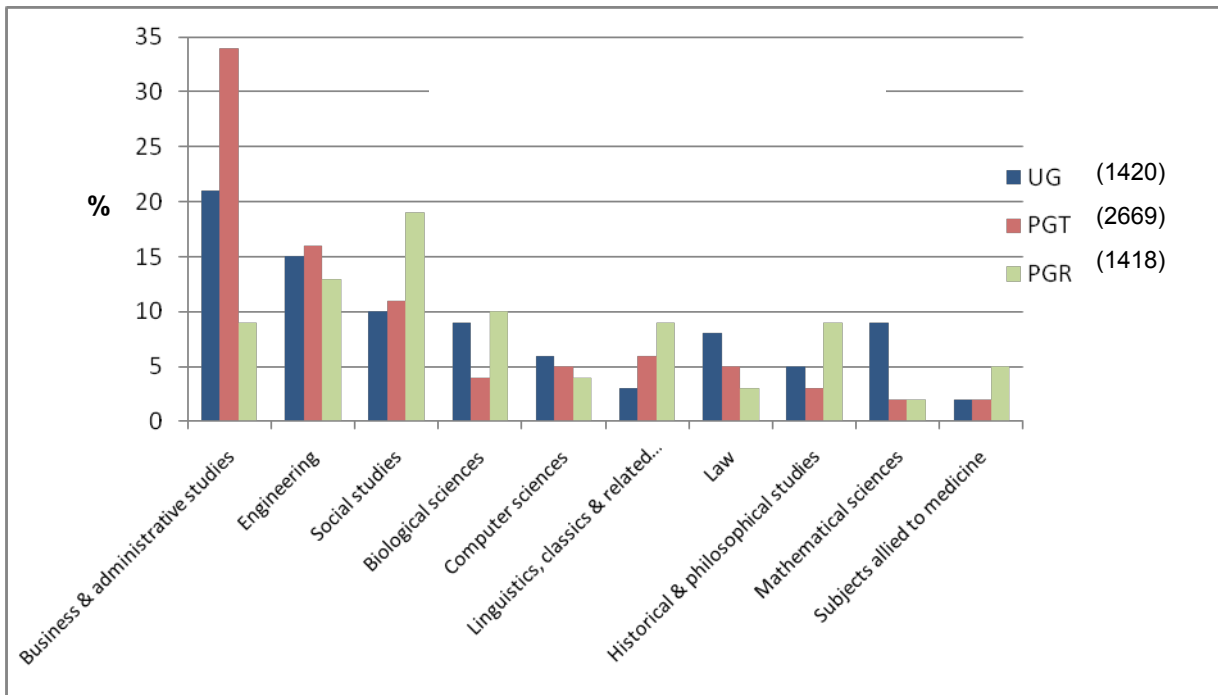
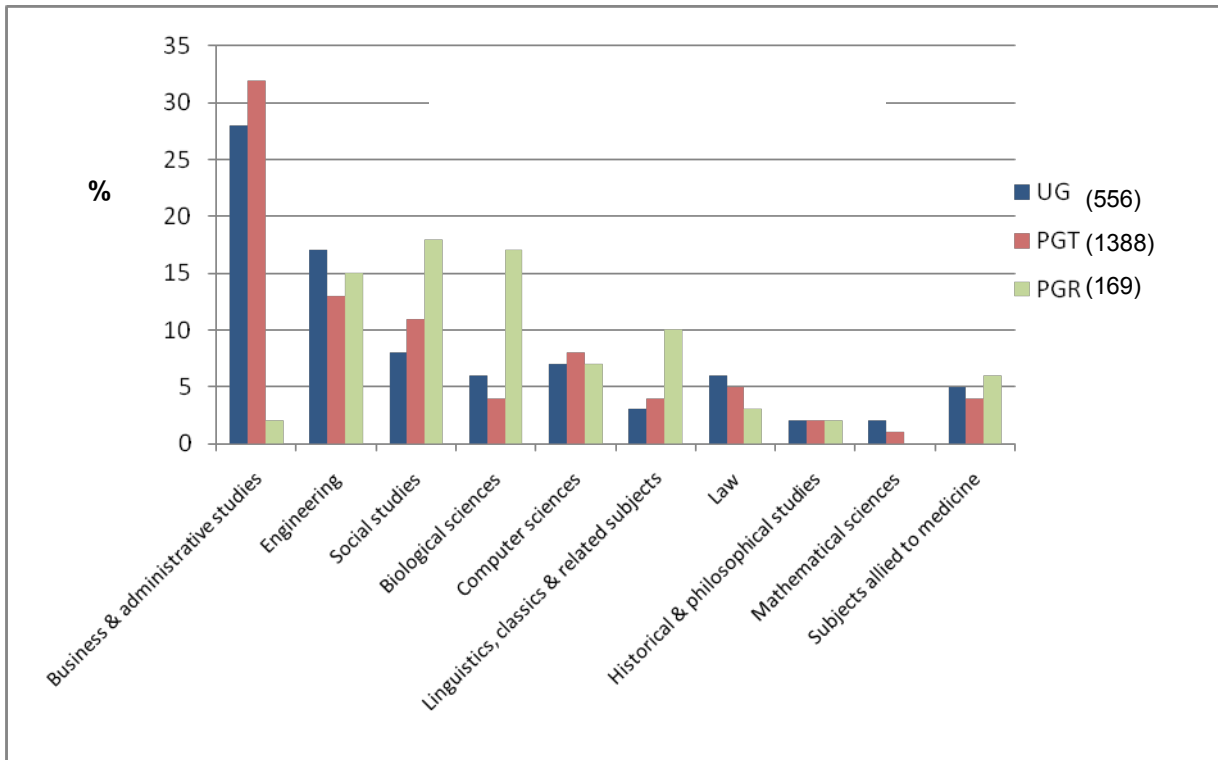

4.2 Employment

According to the definition set out by HESA, the employment rate for graduates is calculated using the proportion of graduates in study and/or some sort of meaningful employment (e.g. full-time, part-time in paid work, self-employed/freelancing or volunteering), out of the total population of graduates who are available for work (see Appendix 6 for the HESA table of employment status). Thus for example, those who are not employed, but not looking for employment, further study or training are not included in the calculation.

Based on this definition, the employment rate for recent graduates from 2010 is 86%, whilst the employment rate for graduates in their third year out of university is much higher, at 95%. These figures are comparable to the results from the i-GO survey last year of 2009 and 2007 graduates. The employment rate for 2009 graduates was 78% and for 2007 graduates, was 95%. These figures are in line with expectations as 2008 and 2007 graduates would have had a longer time since graduation to find employment, or decide to re-engage with study.

Graduates' salary levels and study circumstances are explored in more detail in later sections. However, the flow chart in figure 4.2.1 gives an overview of the employment rates, graduates' locations of their work or study, and their average salary. Appendices 5 and 6 provide a further breakdown for study level (for all four cohorts) and nationality (2010 and 2008 cohorts only).

Looking at the overall figures first in figure 4.2.1, 55% of recent UK graduates are working, 18% are in further study, 14% are working and in further study, whilst 14% are classified as unemployed. Out of those who are working, 22% have remained in the UK with 68% returning home (and 10% going elsewhere overseas). Out of those who are studying, 64% have remained in the UK, with 27% returning home and 9% going elsewhere overseas.

For graduates who left three years ago, 68% are working, 7% are engaged in further study, 21% are working and studying concurrently, whilst only 5% are unemployed. Of those who are working, 17% have remained in the UK. These figures are comparable to graduates from 2009 and 2007 (20% of both cohorts remained in the UK for employment).

It is not possible to provide the location of graduates who are classed as 'unemployed' as this is not asked in the i-GO questionnaire nor in the DLHE questionnaire.

Breaking this down further by study level (see Appendices 7 to 10), it can be seen that a greater proportion of recently graduated UGs remain in further study than

other levels of study (37% of recent graduates with a UG degree are in further study). A graduate with a PGT degree who is working would more than likely return home (72%), and be earning an average salary of £18,295. This can be compared to PGT graduates who remain in the UK to work (19%) and would earn £21,662 on average⁵.

For both cohorts, over three-quarters of Chinese graduates from 2010 and 2008 return home to work (76% of 2010 graduates and 78% of 2008 graduates) and nearly one-fifth remain in the UK to work (see flow chart in Appendices 11 and 12). For Indian graduates, approximately one third who graduated in 2010 remain in the UK to work, and roughly half return home. Indian graduates from 2008 are more likely to be in another country overseas (17%) than recent Indian graduates (9%) if they are working. Salary data for the different nationalities is explored in more detail on pages 30 and 31.

⁵ Caution must be exercised when looking at categories with low base numbers, for example PGR graduates.

Figure 4.2.1 - Overview of employment rates, work and study locations, average, and median salaries of graduates Overall

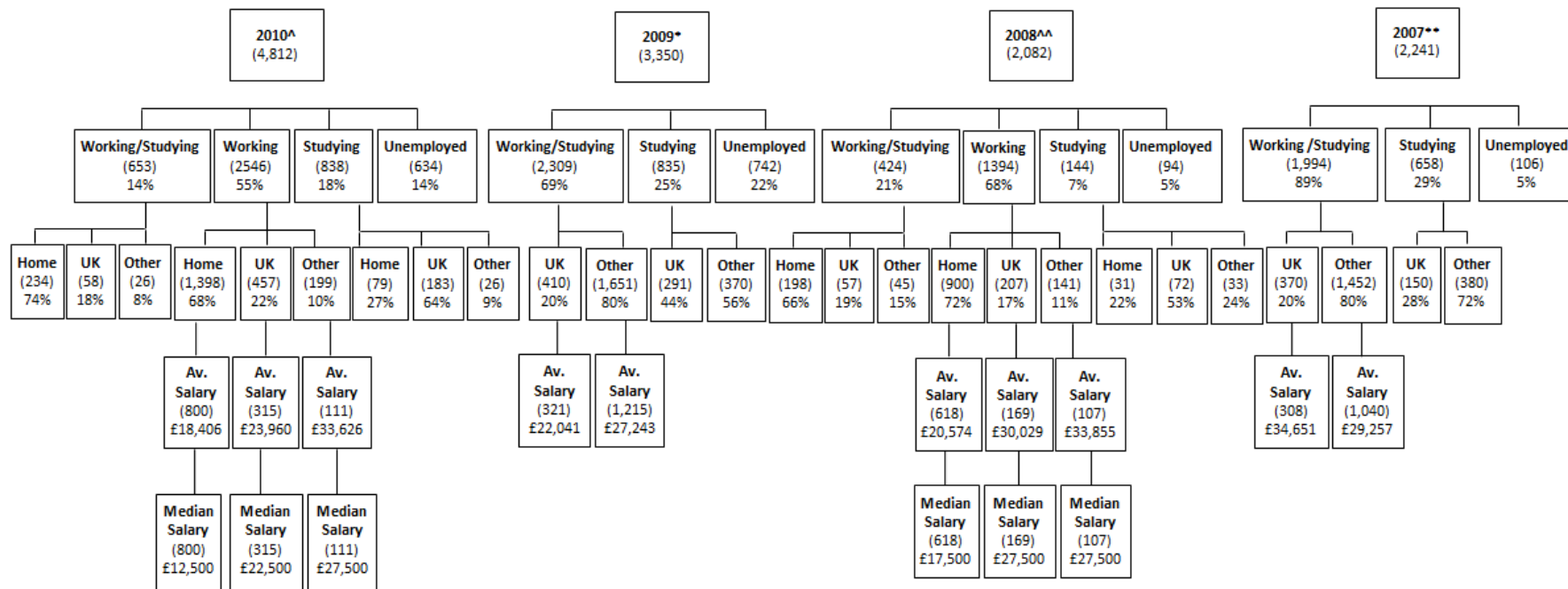

[^]2010 graduates – 6 months after graduation surveyed in 2nd wave

^{^^}2008 graduates – 2 ½ years after graduation surveyed in 2nd wave

^{*} 2009 graduates - 6 months after graduation surveyed in 1st wave (1st wave results did not distinguish between graduates returning home or going elsewhere overseas)

^{**} 2007 graduates – 2 ½ years after graduation surveyed in 1st wave (1st wave results did not distinguish between graduates returning home or going elsewhere overseas)

Employment circumstances

Considering employment circumstances solely and leaving the graduates' studying status aside in this section, it can be seen that UGs from 2010 had the lowest levels in full-time paid work (44%) compared to PGTs and PGRs graduating in 2010 (44%) which increased to 56% when part-time, self-employed work & voluntary work is added (table 4.2.1). PGT graduates had higher levels of full-time employment than PGRs (61% vs. 57%). 79% of PGRs from the 2009 cohort in the first study were in full-time employment.

Table 4.2.1 - Employment circumstances of 2008 and 2010 graduates by study level

Employment circumstance on survey date	Overall		UG		PGT		PGR	
	2010 (4,809)	2008 (2,082)	2010 (1,254)	2008 (548)	2010 (2,610)	2008 (1,369)	2010 (945)	2008 (165)
Employed full-time in paid work	56%	76%	44%	74%	61%	76%	57%	88%
Employed part-time in paid work	6%	4%	7%	5%	6%	3%	6%	4%
Self-employed/freelance	3%	7%	3%	5%	3%	8%	3%	1%
Voluntary work/other unpaid work	2%	1%	2%	2%	2%	1%	1%	1%
Total in employment	67%	88%	56%	86%	72%	88%	67%	94%
Permanently unable to work/retired	0%	0%	0%	0%	0%	0%	0%	0%
Temporarily sick or unable to work/looking after the home or family	<0.5%	<0.5%	0%	0%	0%	<0.5%	1%	0%
Taking time out in order to travel	1%	0.5%	1%	1%	1%	0%	1%	1%
Due to start a job within the next month	3%	1%	2%	0%	4%	1%	2%	0%
Unemployed and looking for employment, further study, training	12%	6%	7%	6%	6%	15%	9%	4%
Not employed but NOT looking for employment, further study or training	8%	2%	16%	2%	2%	2%	15%	1%
Doing something else	8%	4%	19%	5%	4%	6%	5%	1%

Those 2010 undergraduates not in full-time employment were most likely to be either 'not employed and not looking' (16%) or 'doing something else' (19%) with a further 7% 'unemployed and looking for employment, further study of training'. As with the DLHE survey, it is not possible to determine the location of these graduates. PGRs who were not in full-time employment were most likely to be 'not employed but not looking for work' (15%) with 9% reporting that they were unemployed and looking for employment.

2008 UGs show much more robust levels of employment: 74% were in full-time employment, increasing to 86% with part-time and self-employed/freelance added. PGTs from the 2008 cohort had the next highest employment levels: 76% in full-time paid employment rising to 88% with part-time, self-employed/freelance & voluntary work included. PGRs from 2008 had the highest employment rates with 88% in full-time paid employment and 94% including part-time and self-employed/freelance work.

Looking at the results for those in employment, graduates from 2010 who moved from the UK to other international destinations other than their home country were the most likely to be in full-time employment (see table 4.2.2) – the move to another country could have been made as a result of an employment offer. Of these graduates, 89% were in full-time paid work, compared to 77% of those who stayed in the UK and 86% of those returning to their home country.

Table 4.2.2 - Employment circumstances of 2008 and 2010 graduates by location of work

Employment circumstance on survey date	Stayed in UK		Went home		Went overseas	
	2010	2008	2010	2008	2010	2008
Base: all working	(569)	(272)	(1,738)	(1,163)	(250)	(198)
Employed full-time in paid work	77%	89%	86%	88%	89%	87%
Employed part-time in paid work	15%	4%	8%	4%	3%	4%
Self-employed/freelance	4%	6%	4%	8%	4%	6%
Voluntary work/other unpaid work	4%	<0.5%	2%	1%	3%	3%

Graduates from the USA, who were mainly PGR students (figure 4.1.2) were the least likely to be in full-time paid employment (34%), well below the 51% figure for Canadian graduates, and the most likely to be 'not employed not looking' (17%). At

the opposite end of the spectrum, over two thirds of graduates from Taiwan, who were mainly PGT students, were in full-time employment (69%) and graduates from three other Far East locations were among the most likely to be in full-time paid work (Malaysia & Singapore 64%, Hong Kong 62%). For comparison, 59% of Chinese graduates said they were in full-time paid employment, ahead of Pakistan (54%) and India (52%), Nigeria (49%).

Looking across all the countries at the combined (including part-time, self-employed and voluntary work and still disregarding studying status) employment levels for 2010 graduates, the gap between USA graduates and other graduate nationalities narrows: 56% of 2010 USA graduates were in employment compared to 67% for 2010 overall, while Taiwan graduates maintained their leading position with 74% in employment.

Overall just over a fifth of 2010 graduates stayed in the UK to work (22%), approximately two-thirds went back home (68%) and 10% went overseas to another country (also see figure 4.2.1). From table 4.2.4, it can be seen that 2010 graduates from India, Nigeria and Pakistan showed an above average likelihood to stay in the UK (39%, 39% and 41% respectively). Base numbers are quite low for the 2008 graduate cohort (and beyond the top 5 nationalities for the 2010 cohort and therefore it would be unwise to draw general conclusions from the data for most nationalities (table 4.2.3).

Table 4.2.3a - Employment circumstances of 2010 graduates by nationality

Employment circumstance on survey date	Overall	China	India	USA	Malaysia	Nigeria	Canada	Pakistan	Hong Kong	Taiwan	Singapore
	2010 (4,808)	2010 (931)	2010 (596)	2010 (522)	2010 (208)	2010 (205)	2010 (158)	2010 (137)	2010 (142)	2010 (116)	2010 (102)
Employed full-time in paid work	56%	59%	52%	34%	64%	49%	51%	54%	62%	69%	64%
Employed part-time in paid work	6%	2%	6%	16%	3%	8%	8%	8%	4%	3%	5%
Self-employed/freelance	3%	1%	5%	3%	3%	5%	3%	3%	3%	2%	1%
Voluntary work/other unpaid work	2%	2%	2%	3%	0%	5%	2%	1%	2%	0%	0%
Total in employment	67%	64%	65%	56%	70%	67%	66%	64%	71%	74%	70%
Permanently unable to work/retired	0%	0%	0%	0%	0%	0%	0%	0%	0%	0%	0%
Temporarily sick or unable to work/looking after the home or family	0%	0%	1%	0%	0%	0%	0%	0%	1%	1%	0%
Taking time out in order to travel	1%	1%	1%	1%	1%	1%	1%	1%	1%	1%	0%
Due to start a job within the next month	3%	5%	4%	3%	2%	3%	4%	3%	2%	3%	3%
Unemployed and looking for employment, further study, training	12%	12%	21%	10%	12%	20%	9%	19%	10%	13%	6%
Not employed but NOT looking for employment, further study or training	8%	8%	5%	17%	10%	4%	11%	4%	5%	6%	9%
Doing something else	8%	9%	4%	13%	5%	4%	9%	6%	11%	3%	13%

Table 4.2.3b - Employment circumstances of 2008 graduates by nationality

Employment circumstance on survey date	Overall	China	India	USA	Malaysia	Nigeria	Canada	Pakistan	Hong Kong	Taiwan	Singapore
	2008 (2,082)	2008 (221)	2008 (244)	2008 (151)	2008 (147)	2008 (119)	2008 (71)*	2008 (116)	2008 (91)*	2008 (61)*	2008 (28)**
Employed full-time in paid work	76%	89%	67%	61%	85%	71%	75%	72%	85%	87%	75%
Employed part-time in paid work	4%	2%	3%	13%	1%	4%	6%	0%	2%	0%	4%
Self-employed/freelance	7%	4%	13%	7%	3%	6%	7%	11%	7%	7%	4%
Voluntary work/other unpaid work	1%	0%	1%	3%	1%	2%	3%	2%	0%	0%	0%
Total in employment	88%	95%	84%	84%	90%	83%	91%	85%	94%	94%	83%
Permanently unable to work/retired	0%	0%	0%	0%	0%	0%	0%	0%	0%	0%	0%
Temporarily sick or unable to work/looking after the home or family	0%	0%	0%	0%	0%	0%	0%	1%	0%	0%	0%
Taking time out in order to travel	0%	0%	2%	0%	0%	1%	1%	0%	0%	0%	4%
Due to start a job within the next month	1%	0%	4%	1%	0%	2%	3%	1%	0%	0%	0%
Unemployed and looking for employment, further study, training	6%	2%	9%	8%	6%	12%	3%	10%	2%	0%	4%
Not employed but NOT looking for employment, further study or training	2%	1%	2%	3%	2%	0%	0%	2%	1%	3%	0%
Doing something else	4%	2%	3%	4%	3%	5%	3%	2%	3%	3%	11%

*Number of responses is below 100

**Number of responses is below 50

Table 4.2.4a - Location of place of work for 2010 graduates by nationality

Location of place of work	Overall	China	India	USA	Malaysia	Nigeria	Canada	Pakistan	Hong Kong	Taiwan	Singapore
	2010 (1,598)	2010 (466)	2010 (326)	2010 (212)	2010 (115)	2010 (114)	2010 (80)*	2010 (78)*	2010 (81)*	2010 (74)*	2010 (52)*
Stayed in the UK	22%	17%	39%	27%	17%	39%	14%	41%	12%	11%	10%
Home	68%	76%	51%	64%	71%	58%	71%	47%	85%	78%	83%
Went overseas	10%	8%	9%	9%	12%	4%	15%	12%	2%	11%	8%

*Number of responses is below 100

Table 4.2.4b - Location of place of work for 2008 graduates by nationality

Location of place of work	Overall	China	India	USA	Malaysia	Nigeria	Canada	Pakistan	Hong Kong	Taiwan	Singapore
	2008 (981)	2008 (182)	2008 (184)	2008 (118)	2008 (117)	2008 (84)*	2008 (62)*	2008 (85)*	2008 (75)*	2008 (51)*	2008 (23)**
Stayed in the UK	17%	16%	21%	15%	9%	30%	11%	24%	9%	6%	17%
Home	72%	78%	54%	78%	78%	55%	79%	60%	88%	84%	83%
Went overseas	11%	7%	17%	6%	13%	15%	10%	16%	3%	10%	0%

*Number of responses is below 100

**Number of responses is below 50

Organisation type and size

Graduates who studied at UG and PGT level are employed across a range of job industries. Amongst PGR graduates, there is marked tendency for employment in the fields of Education and also Professional, Scientific and Technical Activities (table 4.2.5).

Table 4.2.5 - Standard Industrial Classification (SIC) of current job role for 2008 and 2010 graduates by study level (top 10 sectors reported only)

Standard Industrial Classification	Overall		UG		PGT		PGR	
	2010	2008	2010	2008	2010	2008	2010	2008
	(2,901)	(1,607)	(603)	(416)	(1,680)	(1,057)	(618)	(134)
Education	20%	18%	6%	10%	16%	16%	47%	52%
Financial and Insurance Activities	17%	12%	21%	16%	18%	12%	8%	1%
Professional, Scientific and Technical Activities	15%	15%	14%	12%	15%	15%	18%	22%
Information and Communication	6%	11%	9%	11%	7%	12%	1%	5%
Human Health and Social Work Activities	6%	7%	8%	11%	5%	6%	6%	4%
Manufacturing	7%	7%	6%	8%	8%	8%	5%	3%
Public Administration and Defence; Compulsory Social Security	4%	6%	4%	2%	5%	7%	3%	4%
Other Service Activities	4%	5%	5%	6%	4%	4%	3%	4%
Wholesale and Retail Trade; Repair of Motor Vehicles and Motorcycles	4%	4%	5%	4%	4%	5%	1%	0%
Construction	2%	3%	2%	3%	3%	4%	1%	0%

Focusing on the 2010 cohort, USA (31%) has the highest share of graduates within the Education sector and lie well above the 2010 average of 20% (see table 4.2.6). Overall, the percentage of graduates working in the Information and Communication sector is 5% higher for 2008 graduates, whereas the proportion of graduates involved in Financial and Insurance Activities is 5% lower. For recent Chinese graduates from 2010, the share of Financial and Insurance Activities is considerably higher than for other countries (31%, compared to the 17% average for 2010 cohort).

This is also true of graduates in their third year out where 27% of Chinese graduates are involved in Financial and Insurance Activities compared to the 2008 average of 12%.

Table 4.2.6a - Industrial classification of current job role for 2010 graduates by nationality (top 10 sectors reported only)

Standard Industrial Classification	Overall	China	India	USA	Malaysia	Nigeria
	2010 (2,901)	2010 (522)	2010 (355)	2010 (271)	2010 (137)	2010 (116)
Education	20%	18%	11%	31%	12%	9%
Financial and Insurance Activities	17%	31%	14%	9%	15%	15%
Professional, Scientific and Technical Activities	15%	16%	19%	16%	15%	14%
Manufacturing	7%	8%	10%	2%	10%	8%
Information and Communication	6%	6%	11%	4%	5%	6%
Human Health and Social Work Activities	6%	1%	7%	10%	13%	14%
Wholesale and Retail Trade; Repair of Motor Vehicles and Motorcycles	4%	2%	5%	7%	4%	7%
Public Administration and Defence; Compulsory Social Security	4%	4%	1%	4%	4%	3%
Other Service Activities	4%	2%	7%	7%	4%	6%
Construction	2%	1%	3%	1%	5%	2%

Table 4.2.6b - Industrial classification of current job role for 2008 graduates by nationality (top 10 sectors reported only)

Standard Industrial Classification	Overall	China	India	USA	Malaysia	Nigeria
	2008 (1,607)	2008 (181)	2008 (181)	2008 (117)	2008 (117)	2008 (84)*
Education	18%	12%	15%	25%	16%	10%
Financial and Insurance Activities	12%	27%	10%	4%	7%	13%
Professional, Scientific and Technical Activities	15%	17%	16%	19%	19%	15%
Manufacturing	7%	6%	17%	1%	15%	2%
Information and Communication	11%	13%	15%	8%	3%	11%
Human Health and Social Work Activities	7%	1%	6%	13%	11%	11%
Wholesale and Retail Trade; Repair of Motor Vehicles and Motorcycles	4%	2%	3%	7%	5%	6%
Public Administration and Defence; Compulsory Social Security	6%	4%	3%	3%	1%	5%
Other Service Activities	5%	4%	4%	14%	3%	1%
Construction	3%	1%	2%	2%	6%	4%

*Number of responses is below 100

Job specifications and type

Graduates who have completed a higher level of study are often working for larger organisations (table 4.2.7). This trend may be due to the large proportion of PGRs working in Education and Research roles who are likely to be employed in universities or large organisations with R&D functions.

Table 4.2.7 - Size of organisations employing 2008 and 2010 graduates by study level

Approximate number of employees (all branches/departments)	Overall		UG		PGT		PGR	
	2010	2008	2010	2008	2010	2008	2010	2008
	(1,792)	(1,585)	(431)	(413)	(1,212)	(1,038)	(149)	(134)
1 - 9	6%	8%	9%	7%	6%	9%	0%	3%
10 - 49	15%	13%	18%	14%	14%	13%	9%	5%
50 - 249	17%	16%	16%	17%	18%	15%	11%	15%
250 - 499	9%	9%	9%	7%	9%	9%	10%	11%
500 - 999	8%	8%	7%	8%	8%	8%	7%	7%
1,000 - 4,999	15%	17%	12%	14%	14%	16%	26%	26%
5,000 - 9,999	6%	7%	6%	7%	6%	7%	13%	9%
Over 10,000	16%	17%	16%	19%	17%	17%	13%	12%
Don't know	8%	6%	8%	9%	8%	5%	11%	12%

Table 4.2.8 - Types of contract basis on which 2008 and 2010 graduates were employed by study level

Contract type	Overall		UG		PGT		PGR	
	2010	2008	2010	2008	2010	2008	2010	2008
	(1,832)	(1,611)	(442)	(416)	(1,238)	(1,060)	(152)	(135)
Permanent or open-ended contract	57%	67%	62%	71%	55%	65%	55%	65%
Fixed-term contract -12 months or longer	26%	20%	17%	15%	28%	21%	32%	30%
Fixed-term contract - less than 12 months	7%	3%	6%	4%	7%	3%	9%	1%
Self-employed/freelance	4%	7%	5%	7%	3%	8%	1%	2%
Temporarily, not through an agency	1%	1%	3%	1%	3%	1%	1%	-%
Temporarily, through an agency	3%	1%	1%	1%	1%	1%	1%	-%
Other	3%	1%	5%	1%	2%	1%	2%	1%

More than 50% of all study levels are employed on a permanent or open-ended contract basis (table 4.2.8). Compared to the 2008 cohort (67% overall), the 2010 cohort shows less permanent employment across all levels of study (57% overall). This is most likely due to the bias towards Chinese PGT graduates on a fixed-term contract of 12 months or longer when they have sought paid employment back home.

Table 4.2.9a - Types of contract basis on which 2010 graduates were employed by nationality

Contract type	Overall	China	India	USA	Malaysia	Nigeria
	2010 (1,832)	2010 (303)	2010 (233)	2010 (132)	2010 (100)	2010 (92)*
Permanent or open-ended contract	57%	28%	66%	53%	69%	63%
Fixed-term contract -12 months or longer	26%	59%	13%	12%	16%	12%
Fixed-term contract - less than 12 months	7%	6%	5%	17%	6%	4%
Self-employed/ freelance	4%	3%	7%	2%	4%	3%
Temporarily, not through an agency	1%	2%	4%	5%	1%	4%
Temporarily, through an agency	3%	1%	2%	1%	1%	8%
Other	3%	2%	4%	9%	3%	5%

*Number of responses is below 100

Table 4.2.9b - Types of contract basis on which 2008 graduates were employed by nationality

Contract type	Overall	China	India	USA	Malaysia	Nigeria
	2008 (1,611)	2008 (180)	2008 (180)	2008 (116)	2008 (116)	2008 (83)*
Permanent or open-ended contract	67%	46%	68%	61%	80%	70%
Fixed-term contract - 12 months or longer	20%	46%	13%	14%	13%	11%
Fixed-term contract - less than 12 months	3%	2%	2%	9%	4%	5%
Self-employed/ freelance	7%	5%	14%	9%	3%	10%
Temporarily, not through an agency	1%	1%	1%	1%	<0.5%	1%
Temporarily, through an agency	1%	1%	1%	3%	0%	1%
Other	1%	1%	2%	2%	<0.5%	2%

*Number of responses is below 100

The majority of the students in all surveyed nationalities are enrolled in permanent or open ended work (table 4.2.9). The only exception are the Chinese, where 59% of the 2010 cohort (46% in 2008) was on a fixed-term contract lasting 12 months or longer. The proportion of fixed-term contracts lasting less than 12 months is the highest in North America for the 2010 cohort (17% in the US). The highest percentage of temporary employment (either through or agency or not) rests with Nigerians (12% in 2010). Self-employment/freelance was lower for all level of studies in the 2010 cohort compared to 2008, and remains under 10% for all level of studies in both cohorts. In 2010, the lowest number of self-employed/freelance was Canada.

Nine out of the top ten occupation classifications for 2010 and 2008 graduates listed in table 4.2.10 are deemed to represent graduate-level jobs. Graduate-level jobs are defined by HESA as working in the first three major SOC groups⁶, covering the 'traditional', 'modern' and 'new' definitions of graduate-level jobs⁷:

- 1 Managers and Senior Officials,
- 2 Professional Occupations,

⁶ <http://www.hesa.ac.uk/index.php/content/view/102/143/1/9/>

⁷ <http://www2.warwick.ac.uk/fac/soc/ier/research/completed/7yrs2/rp6.pdf>

- 3 Associate Professional and Technical Occupations.

These job groupings are comprised of the following types of jobs:

- Corporate managers
- Managers and proprietors in agriculture and services
- Science and technology professionals
- Health professionals
- Teaching and research professionals
- Business and public service professionals
- Science and technology associate professionals
- Health and social welfare associate professionals
- Protective service occupations
- Culture, media and sports occupations
- Business and public service associate professionals

Table 4.2.10 - Standard Occupation Classification (SOC) of current job role for 2008 and 2010 graduates (top 10 classifications listed here) by study level

Standard Occupational Classification	Overall		UG		PGT		PGR	
	2010 (2,692)	2008 (1,417)	2010 (545)	2008 (356)	2010 (1,550)	2008 (949)	2010 (597)	2008 (112)
Business and Public Service Associate Professionals [^]	19%	15%	20%	14%	21%	17%	12%	3%
Science and Technology Professionals [^]	15%	17%	16%	16%	12%	15%	22%	36%
Teaching and Research Professionals [^]	17%	13%	4%	6%	13%	12%	40%	47%
Business and Public Service Professionals [^]	14%	16%	17%	15%	15%	17%	7%	4%
Corporate Managers [^]	8%	11%	5%	7%	9%	14%	6%	4%
Administrative Occupations	8%	8%	12%	13%	9%	7%	2%	3%
Health Professionals [^]	3%	4%	6%	6%	2%	3%	3%	2%

Standard Occupational Classification	Overall		UG		PGT		PGR	
	2010 (2,692)	2008 (1,417)	2010 (545)	2008 (356)	2010 (1,550)	2008 (949)	2010 (597)	2008 (112)
Science and Technology Associate Professionals [^]	3%	3%	3%	5%	3%	3%	12%	0%
Managers and Proprietors in Agriculture and Services [^]	2%	2%	1%	4%	3%	2%	1%	0%
Culture, Media and Sports Occupations [^]	3%	2%	3%	3%	3%	3%	2%	0%

[^] = graduate-level job as defined by HESA

Figure 4.2.2 (and table 4.2.10) shows the proportion of graduates in graduate-level jobs by level of study for 2010 graduates. As seen in the pie charts, the higher the level of study, the higher the proportion of graduates in graduate-level job as expected. The figures for 2008 graduates are identical except for PGT graduates where 13% are employed in non graduate-level jobs and 87% in graduate-level jobs, a slightly higher proportion than 2010 graduates.

Looking at the top three nationalities in figure 4.2.3 (and table 4.2.11) for the 2010 cohort, a very high percentage of Chinese, Indian, and USA graduates are involved in graduate-level jobs.

UG and PGT graduates from 2008 and 2010 are employed across a range of roles, with the largest grouping being Business and Public Service Associate Professionals followed by Science and Technology Professionals and Teaching and Research Professionals (table 4.2.10). PGRs were primarily engaged as Teaching and Research professionals in both cohorts, with 40% (2010) and 47% (2008) of this small sample group indicating they were employed in this type of role as presumably they would be working towards an academic career. The share of PGRs in Science and Technology Professions (22% of 2010 cohort and 36% of 2008 cohort) is significantly higher (statistically) compared to PGTs (12% of 2010 and 15% of 2008) and UGs (16% of 2010 and 2008 cohorts).

Figure 4.2.2a - Proportion of 2010 graduates in graduate-level jobs by level of study

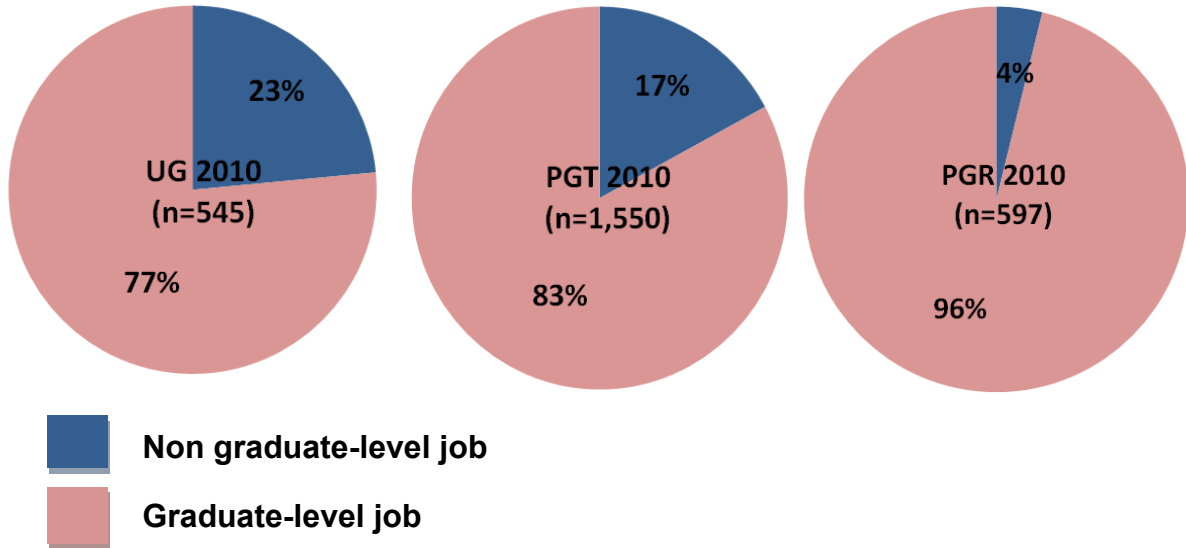

Figure 4.2.2b - Proportion of 2008 graduates in graduate-level jobs by level of study

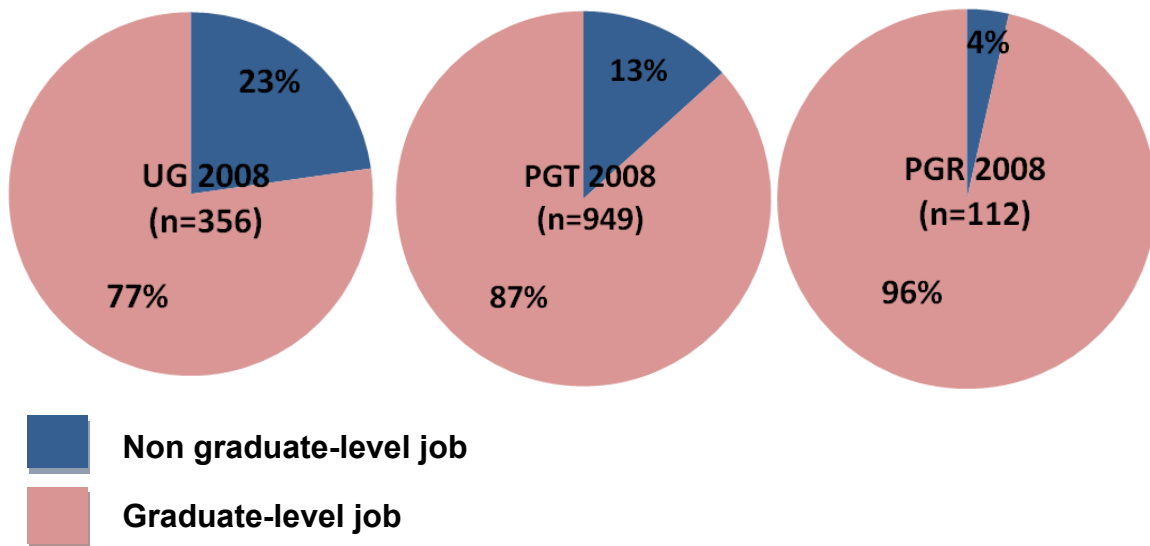
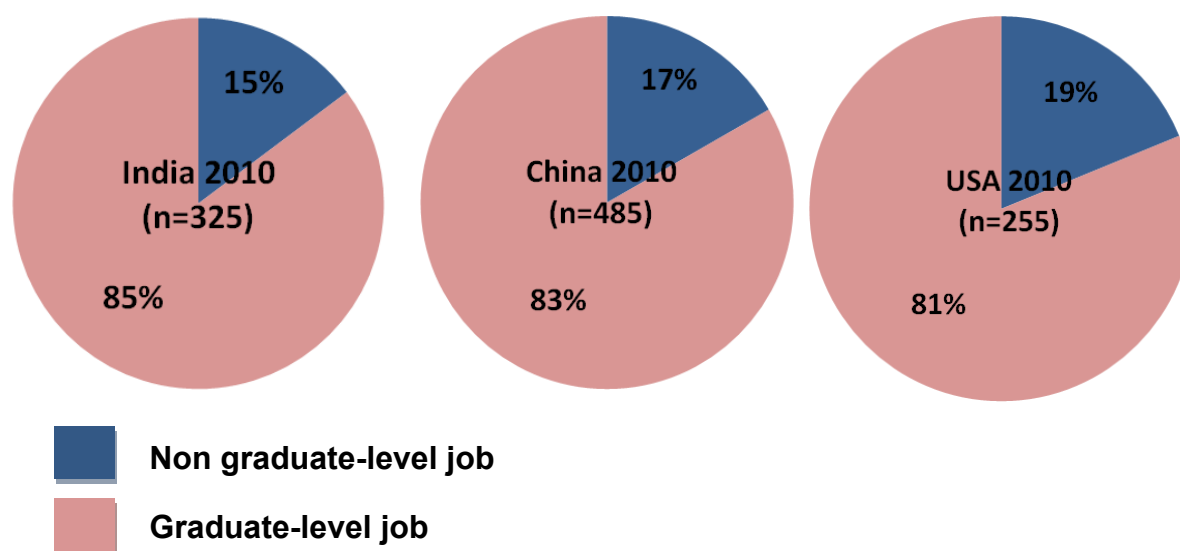

Figure 4.2.3 - Proportion of 2010 graduates in graduate-level jobs by nationality**Table 4.2.11a - Standard Occupation Classification (SOC) of current job role for 2010 graduates (top 10 classifications listed here) by nationality**

Standard Occupational Classification	Overall	China	India	USA	Malaysia	Nigeria
	2010 (2,692)	2010 (485)	2010 (325)	2010 (255)	2010 (125)	2010 (104)
Business and Public Service Assoc. Professionals [^]	19%	25%	23%	13%	12%	20%
Teaching and Research Professionals [^]	17%	15%	8%	28%	13%	8%
Science and Tech. Professionals [^]	15%	13%	20%	9%	19%	22%
Business and Public Service Professionals [^]	14%	13%	15%	7%	14%	6%
Corporate Managers [^]	8%	10%	8%	6%	6%	9%
Administrative Occupations	8%	10%	7%	7%	10%	7%
Health Professionals [^]	3%	1%	2%	5%	10%	6%
Science and Tech. Associate Professionals [^]	3%	2%	4%	5%	2%	3%
Culture, Media and Sports Occupations [^]	3%	2%	2%	5%	1%	1%
Managers and Proprietors in Agric. and Services [^]	2%	3%	2%	1%	2%	3%

[^] = graduate-level job as defined by HESA

Table 4.2.11b - Standard Occupation Classification (SOC) of current job role for 2008 graduates (top 10 classifications listed here) by nationality

Standard Occupational Classification	Overall	China	India	USA	Malaysia	Nigeria
	2008 (1,417)	2008 (151)	2008 (153)	2008 (108)	2008 (106)	2008 (75)*
Business and Public Service Assoc. Professionals [^]	15%	17%	14%	10%	10%	21%
Teaching and Research Professionals [^]	13%	9%	6%	17%	14%	7%
Science and Tech. Professionals [^]	17%	15%	31%	9%	19%	24%
Business and Public Service Professionals [^]	16%	23%	18%	15%	14%	13%
Corporate Managers [^]	11%	10%	14%	7%	9%	15%
Administrative Occupations	8%	11%	2%	7%	10%	4%
Health Professionals [^]	4%	1%	1%	7%	8%	3%
Science and Tech. Associate Professionals [^]	3%	3%	5%	2%	4%	5%
Culture, Media and Sports Occupations [^]	2%	1%	1%	6%	2%	-%
Managers and Proprietors in Agric. and Services [^]	2%	2%	3%	4%	2%	-%

*Number of responses is below 100

[^] = graduate-level job as defined by HESA

For the 2010 cohort, Chinese (25%) and Indian (23%), graduates have the highest share of Business and Public Service Associate Professionals (table 4.2.11). The group of Teaching and Research Professionals is the highest amongst graduates from the USA (28%). Malaysia and Nigeria's biggest professional group is Science and Technology Professionals (19% and 22% respectively).

Table 4.2.12 - Management responsibilities for 2008 and 2010 graduates by study level

Job responsibilities	Overall		UG		PGT		PGR	
	2010 (1,771)	2008 (1,564)	2010 (425)	2008 (397)	2010 (1,199)	2008 (1,033)	2010 (147)	2008 (134)
I manage myself and others	15%	21%	15%	21%	15%	23%	16%	14%
I manage myself and my own work	30%	35%	28%	28%	28%	34%	48%	60%
My work is mainly given to me by others	40%	34%	40%	36%	41%	35%	29%	19%
All my work is given to me by others	15%	10%	16%	15%	15%	9%	7%	7%

Compared to 2008, the overall share of those who get all their work given by others is greater by 5% (at 15%), whereas the share of those who manage themselves and their own work is less by the same rate (table 4.2.12). The group with the highest level of job responsibility is the group of PGRs for both cohorts where they manage themselves and their own work (48% for 2010 and 60% for 2008 graduates). This shows a natural career progression of older graduates having more responsibility in the workplace by managing themselves and others and is true amongst the different nationalities (table 4.2.13⁸).

⁸ Caution is advised when looking at nationalities with low base numbers.

Table 4.2.13a - Management responsibilities for 2010 graduates by nationality

Job responsibilities	Overall	China	India	USA	Malaysia	Nigeria
	2010 (1,771)	2010 (293)	2010 (224)	2010 (129)	2010 (96)*	2010 (87)*
I manage myself and others	15%	6%	18%	8%	14%	17%
I manage myself and my own work	30%	20%	33%	26%	28%	29%
My work is mainly given to me by others	40%	51%	37%	50%	50%	34%
All my work is given to me by others	15%	23%	13%	17%	8%	20%

*Number of responses is below 100

Table 4.2.13b - Management responsibilities for 2008 graduates by nationality

Job responsibilities	Overall	China	India	USA	Malaysia	Nigeria
	2008 (1,564)	2008 (173)	2008 (173)	2008 (113)	2008 (115)	2008 (78)*
I manage myself and others	21%	13%	23%	15%	23%	32%
I manage myself and my own work	35%	26%	43%	31%	32%	31%
My work is mainly given to me by others	34%	46%	27%	38%	32%	28%
All my work is given to me by others	10%	16%	7%	16%	12%	9%

*Number of responses is below 100

Salary

Salaries for those who graduated in 2010 and 2008 have been calculated for those who stated that they are currently working only. Average salaries are displayed by study level, location of work, and by nationality and can be found in tables 4.2.14 and 4.2.15. Median salaries are also displayed in the flow charts in figure 4.2.1, Appendices 7 to 11, and figure 4.2.4 shows the distribution of salaries for the top three nationalities. These salary calculations have excluded outliers using the general rule that any salary above £100,000 for recent graduates (i.e. the 2010 cohort) have been excluded, and any salary above £200,000 for graduates in their third year out (i.e. the 2008 cohort), have been excluded. The difference in the exclusion criteria is to allow for career (and hence salary) progression.

In general, salary data is in line with expectations; the higher the university degree gained by the graduate, the higher the salary, and the greater the amount of time the graduate has left university, the greater the salary (see table 4.2.14 below).

However, for graduates working elsewhere overseas, the difference between average starting salaries for 2010 graduates, is very similar to salaries for graduates who left university 2½ years ago.

Table 4.2.14 - Estimated average salary for 2008 and 2010 graduates by study level and location

Annual pay to the nearest thousand GBP, before tax	UG		PGT		PGR		Location					
	2010 (242)	2008 (220)	2010 (851)	2008 (623)	2010 (131)	2008 (51)	UK		Home		Other	
							2010 (315)	2008 (169)	2010 (800)	2008 (618)	2010 (111)	2008 (107)
Mean salary (£) (rounded)	18,278	22,238	20,443	23,844	31,660	32,647	23,960	30,029	18,406	20,574	33,626	33,855

Overall, the salary levels for the top three nationalities as seen in table 4.2.15 does not seem to be remarkable. However, when looking at Appendices 11 and 12 which compare the average salaries for these graduates depending on their location of work, great differences occur for Chinese and Indian graduates who return home to work and who stay in the UK to work. A 2010 graduate from China who remains in the UK would earn, on average, £26,125, compared to those who return home and earn, on average, £9,675.

The difference in annual salary between returning home to India and staying in the UK for employment is marked for both 2010 and 2008 graduates. A 2008 graduate from India who remains in the UK would earn, on average, £32,071, compared to those who return home and earn a mean salary of £10,867. A 2010 Indian graduate would earn an average salary of £22,500 if staying in the UK, compared to earning £13,214, if returning home.

A series of country-specific career guides⁹ have been produced by i-graduate with ELM for the UK's Association of Graduate Careers Advisory Services (AGCAS).

⁹ Career guides, http://www.agcas.org.uk/agcas_resources/132-Starting-Your-Career-In-Country-Guides-for-International-Students

According to the guides for China, India, and the US, average graduate starting salaries were respectively £4,152, £4,394, and £24,514 in 2010. In this study, graduates of these nationalities returning home appear to be earning a much greater amount.

Table 4.2.15 - Estimated average salary for 2008 and 2010 graduates by top three nationalities

Annual pay to nearest thousand GBP, before tax	Overall		China		India		USA	
	2010	2008	2010	2008	2010	2008	2010	2008
	(1,226)	(894)	(182)	(113)	(143)	(101)	(205)	(65)
Mean salary (£) (rounded)	21,211	23,951	14,875	17,276	19,702	20,222	26,298	25,192

*Number of responses is below 100

The International Education Premium – employment in UK

The average salary of a 2010 UK graduate was £20,000¹⁰ six months after graduation. This study suggests the average salary of a 2010 international (non-EU) graduate with an UG degree, working in the UK, six months after graduation is £24,462¹¹. The difference is the International Education Premium for employment in the UK. Previous research has established that employers place a premium on graduates whose experience and education demonstrate a sense of global context¹². Now we have a measure of the extent of that premium: £4,462 in the first year post-graduation. That is a premium of close to 25% on the average graduate salary.

If the International Education Premium can be sustained across the course of a career (subsequent i-graduate research to demonstrate this), by the age of 42, the average cumulative international education premium in the UK for an international graduate would be £88,924: a healthy return on investment.

Of course this raises the question of work authorisation, immigration and visas. Only the most highly-skilled graduates will be able to stay in the UK in the long term. This is reinforced by the findings of this study for graduates who are in their third year after graduation, by which time non-EU graduates will require a working visa to be employed in the UK. By this time their average salary is £31,358 (median £27,500). There is no directly comparable indicator for UK graduates. But the leap in average earnings of £6,896 and an average increase of 28% across 2 years suggests these graduates are highly valued by UK employers. This is reinforced by the fact that in

¹⁰ DLHE data: average salary of UK-domiciled graduates with an undergraduate degree – http://www.hesa.ac.uk/index.php?option=com_content&task=view&id=1899&Itemid=239

¹¹ Appendix 7. Median salary £22,500

¹² Archer, W., & Davison, J. (2009) Graduate Employability: What do employers think and want. 'Global Horizons' report: <http://www.cihe.co.uk/wp-content/themes/cihe/document.php?file=0802Grademployability.pdf>

most cases employers will have had to secure a work authorisation for these individuals.

Inevitably some might argue that these international graduates are taking the jobs of UK nationals. We would argue the reverse – these individuals will be sustaining and creating jobs for UK graduates, by enabling UK employers to compete more effectively in a global context.

Currently fewer than 1% of UK students study overseas¹³, so employers seeking a sense of global context will inevitably favour international graduates over UK graduates with a domestic education, 99% of whose CVs today might carry the implication of parochial perspective.

The UK education premium – employment in home country

Political arguments rage ad-infinitum about immigration and brain drain. This study suggests that in the year following graduation the vast majority of UK-educated international graduates in employment are not working in the UK. They are either working in their home country or a third country.

While the figures are indicative and not unequivocal, the data suggests that UK-educated Chinese graduates returning home for employment command a premium of % over the average graduate starting salary of £4,152 in China and UK-educated graduates returning to India command a premium of % over the average graduate starting salary of £4,394 in India.

For graduates returning to work in the United States the UK Education Premium is smaller for three reasons: firstly, average graduate salaries in the US are high already; secondly many US students studying in the UK will be on study abroad or student exchange programmes and thirdly, the generally perceived difference in the quality of higher education is smaller.

The ‘Global Graduate’ Premium – working in a third country

While the numbers of international graduates going to work in a third country are small, these individuals will tend to be the most highly prized by international employers: the major management consultancies, financial institutions, extractors and producers... and of course, educators. Graduates who are globally mobile and multilingual will be most attractive to multinationals when they demonstrate a more-than-bilateral comparative understanding; not just the differences between their home country and the UK, but an ability to work effectively in other, unfamiliar environments.

¹³ Davidson, M. (2011). Chief Executive of the British Council, Speech to US and UK university presidents and vice chancellors, 19th October, 2011.

Table 4.2.16a - Banded salaries for 2008 and 2010 graduates by study level

Annual pay to the nearest thousand GBP (£), before tax	UG		PGT		PGR	
	2010 (505)	2008 (403)	2010 (1332)	2008 (1019)	2010 (409)	2008 (125)
Less than £4,999	16%	9%	10%	6%	7%	4%
£5,000 to £9,999	10%	12%	16%	12%	4%	10%
£10,000 to £19,999	17%	19%	21%	19%	12%	14%
£20,000 to £29,999	19%	14%	15%	16%	25%	14%
£30,000 to £39,999	7%	10%	6%	10%	22%	20%
£40,000 to £49,999	2%	7%	4%	5%	10%	6%
£50,000 to £69,999	1%	3%	3%	4%	7%	6%
£70,000 to £99,999	1%	1%	2%	2%	2%	2%
£100,000 to £149,999	<0.5%	0%	1%	<0.5%	<0.5%	0%
£150,000 to £199,999	0%	<0.5%	<0.5%	<0.5%	<0.5%	1%
Over £200,000	<0.5%	0%	<0.5%	<0.5%	1%	2%
I'd rather not say	26%	25%	22%	25%	9%	22%

There have been strong suggestions to make the question regarding a graduate's salary, compulsory in the DLHE survey. The reason for the change is due to the large number of non-responses to this question. Similarly with this study, an overwhelming number of graduates would prefer not to disclose their salary levels and will choose the option of "I'd rather not say".

On closer examination of the salary data, when looking at the salary bands of 2010 graduates, approximately one-third of responses regardless of level of study are banded between £10,000 and £29,999 (table 4.2.16). PGRs report a notably higher average and median salary than all other levels of study.

Table 4.2.16b - Banded salaries for 2008 and 2010 graduates by location

Annual pay to the nearest thousand GBP (£), before tax	Location					
	UK		Home Country		Other	
	2010 (438)	2008 (261)	2010 (1416)	2008 (1100)	2010 (182)	2008 (186)
Less than £4,999	6%	2%	13%	8%	8%	5%
£5,000 to £9,999	5%	2%	17%	15%	5%	6%
£10,000 to £19,999	24%	11%	18%	22%	16%	12%
£20,000 to £29,999	34%	33%	10%	11%	15%	21%
£30,000 to £39,999	13%	23%	6%	7%	13%	15%
£40,000 to £49,999	4%	8%	3%	5%	8%	9%
£50,000 to £69,999	2%	5%	2%	4%	9%	6%
£70,000 to £99,999	1%	1%	2%	1%	5%	4%
£100,000 to £149,999	<0.5%	<0.5%	1%	<0.5%	1%	1%
£150,000 to £199,999	<0.5%	<0.5%	<0.5%	<0.5%	1%	1%
Over £200,000	<0.5%	<0.5%	<0.5%	<0.5%	1%	<0.5%
I'd rather not say	10%	15%	27%	27%	19%	20%

For location of work (table 4.2.16b), the majority of respondents who have stayed in the UK or have gone elsewhere internationally, have an annual pay of between £20,000-29,999. Whilst for graduates who have returned to their home country, salaries are most likely to be in the salary band below of £10,000-19,999 (22% in 2008 and 18% in 2010).

Table 4.2.17a - Banded salaries for 2010 graduates by nationality

Annual pay to the nearest thousand GBP (£), before tax	Overall	China	India	USA	Malaysia	Nigeria
	2010 (2,246)	2010 (357)	2010 (260)	2010 (200)	2010 (111)	2010 (93)*
Less than £4,999	11%	13%	11%	12%	9%	9%
£5,000 to £9,999	12%	25%	11%	6%	25%	13%
£10,000 to £19,999	19%	17%	20%	16%	16%	23%
£20,000 to £29,999	18%	13%	19%	23%	14%	15%
£30,000 to £39,999	9%	7%	8%	12%	5%	9%
£40,000 to £49,999	5%	2%	3%	10%	3%	4%
£50,000 to £69,999	3%	2%	2%	2%	2%	1%
£70,000 to £99,999	2%	0%	2%	3%	1%	1%
£100,000 to £149,999	1%	0%	0%	2%	0%	0%
£150,000 to £199,999	<0.5%	1%	0%	0%	0%	0%
Over £200,000	<0.5%	0%	0%	1%	0%	0%
<i>I'd rather not say</i>	20%	21%	24%	15%	24%	26%

*Number of responses is below 100

Table 4.2.17b - Banded salaries for 2008 graduates by nationality

Annual pay to the nearest thousand GBP (£), before tax	Overall	China	India	USA	Malaysia	Nigeria
	2008 (1,547)	2008 (176)	2008 (175)	2008 (114)	2008 (111)	2008 (80)*
Less than £4,999	6%	5%	7%	6%	7%	3%
£5,000 to £9,999	12%	16%	18%	5%	29%	4%
£10,000 to £19,999	19%	27%	13%	19%	14%	13%
£20,000 to £29,999	16%	14%	17%	18%	5%	21%
£30,000 to £39,999	11%	10%	10%	14%	6%	10%
£40,000 to £49,999	6%	1%	5%	8%	4%	14%
£50,000 to £69,999	4%	2%	2%	2%	2%	3%
£70,000 to £99,999	2%	1%	1%	3%	0%	5%
£100,000 to £149,999	<0.5%	0%	0%	0%	0%	0%
£150,000 to £199, 999	<0.5%	0%	0%	0%	0%	0%
Over £200,000	<0.5%	1%	1%	0%	0%	0%
<i>I'd rather not say</i>	24%	23%	27%	25%	33%	29%

*Number of responses is below 100

When broken down by nationality (table 4.2.17), a large proportion of respondent salaries lie between £10,000 and £29,999 (37% for 2010 cohort, 35% for 2008 cohort).

A notable exception where a large proportion of the response lies outside of these two salary bands for 2010 are for Chinese and Malaysian graduates where 25% of respondents reported their annual salary to be between £5,000-£9,999.

The graph below illustrates the distribution of salaries among the top three nationalities of graduates. It can be seen that virtually no 2010 graduates from China are earning a salary above £70,000 and one third are earning a wage ranging between £5,000 to £9,999. This is contrasted with graduates from the USA where 27% are earning within the £20,000 to £29,999 bracket.

Figure 4.2.4 - Percentage of 2010 graduates from China, India and the USA and their salary in a given band

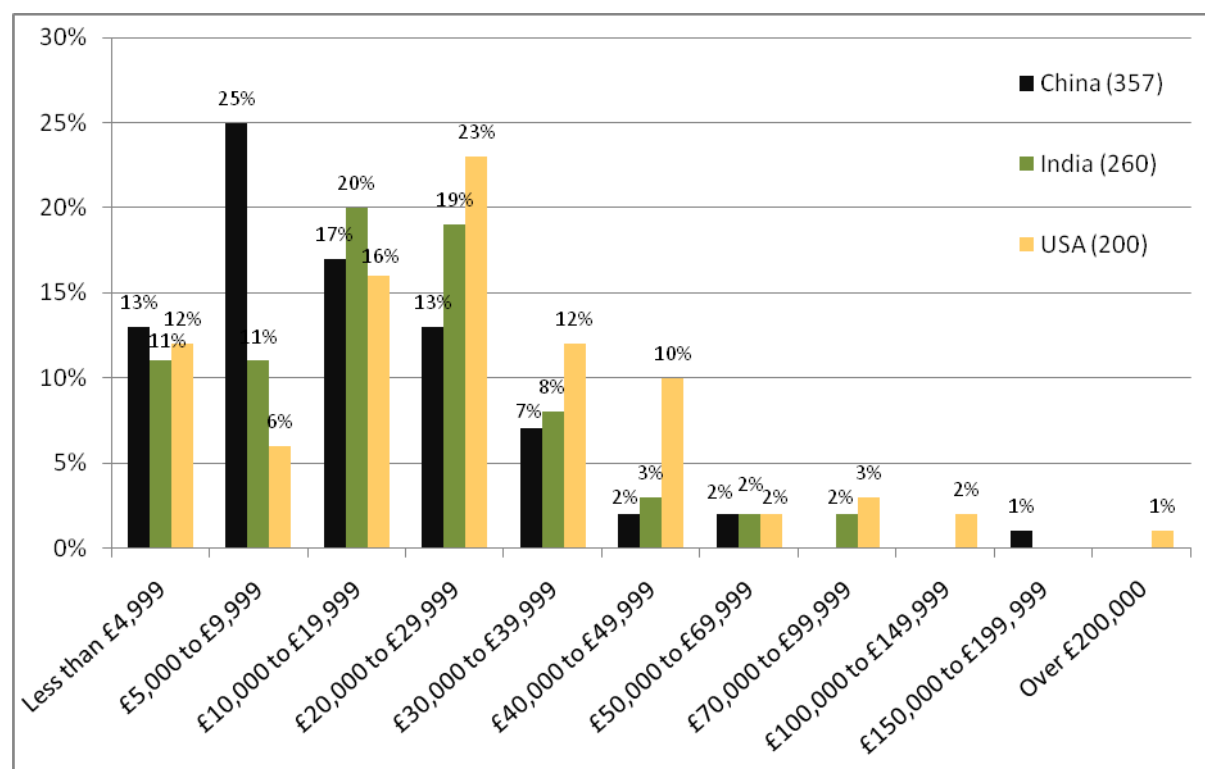

Perceptions and motivations

Table 4.2.18a - Perceptions of income for 2008 and 2010 graduates by study level

Perceptions of income	Overall		UG		PGT		PGR	
	2010 (1820)	2008 (1615)	2010 (419)	2008 (134)	2010 (1356)	2008 (1153)	2010 (193)	2008 (146)
Well above average	9%	12%	7%	14%	10%	12%	22%	16%
Above average	32%	38%	29%	49%	36%	41%	35%	39%
Average	41%	37%	43%	29%	40%	35%	33%	32%
Below average	13%	11%	16%	5%	11%	10%	8%	10%
Well below average	4%	3%	5%	3%	3%	2%	3%	3%

PGT and PGR graduates were the ones who perceived that they earned an above average salary the most, at 36% and 39% respectively (for 2010 graduates).

Table 4.2.18b - Perceptions of income for 2008 and 2010 graduates by location

Perceptions of income	Overall		Stayed in UK		Went home		Went overseas	
	2010	2008	2010	2008	2010	2008	2010	2008
	(1,820)	(1,615)	(318)	(269)	(1,356)	(1,153)	(1,46)	(193)
Well above average	9%	12%	2%	4%	10%	12%	16%	22%
Above average	32%	38%	16%	26%	36%	41%	39%	35%
Average	41%	37%	49%	51%	40%	35%	32%	33%
Below average	13%	11%	24%	15%	11%	10%	10%	8%
Well below average	4%	3%	9%	4%	3%	2%	3%	3%

The cohort that perceives they earn “above average” and “well above average” is highest (39%) among those who went elsewhere internationally for work (table 4.2.18), especially for those who graduated in 2008 (22%). Most graduates who either stay in the UK, went home, or went elsewhere to work, do not think that they earn “well below average” as this figure remains under 10%. The highest proportion who perceived their income to be “average” were those who stayed in the UK (49% of 2010 cohort and 51% of 2008 cohort) and went home to work (40% of 2010 cohort and 35% of 2008 cohort).

Table 4.2.19a - Perceptions of income for 2010 graduates by nationality

Perceptions of income	Overall	China	India	USA	Malaysia	Nigeria
	2010	2010	2010	2010	2010	2010
	(1,820)	(303)	(230)	(130)	(100)	(86)*
Well above average	9%	11%	10%	2%	2%	12%
Above average	32%	34%	30%	19%	32%	26%
Average	41%	44%	41%	37%	47%	47%
Below average	13%	10%	12%	31%	16%	12%
Well below average	4%	3%	7%	11%	3%	5%

*Number of responses is below 100

Table 4.2.19b - Perceptions of income for 2008 graduates by nationality

Perceptions of income	Overall	China	India	USA	Malaysia	Nigeria
	2008 (1,615)	2008 (181)	2008 (179)	2008 (117)	2008 (116)	2008 (83)*
Well above average	12%	8%	11%	3%	6%	19%
Above average	38%	49%	39%	21%	32%	36%
Average	37%	36%	41%	44%	53%	35%
Below average	11%	7%	8%	25%	8%	7%
Well below average	3%	1%	2%	7%	2%	2%

*Number of responses is below 100

Overall, a large proportion from the 2010 cohort stated that they earn an average wage (table 4.2.19). A greater percentage from the 2008 cohort (with the exception of Nigerian graduates) perceive that they earn an above average wage than graduates from the 2010 cohort. Graduates of the 2010 cohort perceive that they earn comparatively high wages (well above average/average) in China (45%) and comparatively low wages (below average/well below average) in the USA (42%).

Table 4.2.20 - Perceptions of “most important factor to current employer” for 2008 and 2010 graduates by location

What was most important to your employer?	Overall		Stayed in UK		Went home		Went overseas	
	2010 (1,766)	2008 (1,563)	2010 (310)	2008 (258)	2010 (1,313)	2008 (1,113)	2010 (143)	2008 (192)
A qualification from a university/college in the UK	18%	18%	18%	26%	19%	16%	17%	16%
A qualification from my university	5%	4%	5%	4%	5%	4%	2%	5%
The subject(s) studied	32%	32%	33%	29%	31%	32%	42%	33%
The level of study	30%	32%	19%	20%	32%	35%	29%	32%
Don't know	15%	14%	24%	21%	14%	12%	10%	14%

The subject(s) studied is considered to be the most important factor for employers (32% in both cohorts overall), followed by the level of study (30% in 2010 and 32% in 2008 overall; table 4.2.20). 42% of the 2010 cohort, who went elsewhere overseas to

work, believe that the subject(s) studied was most important to their employer (10% above average). The university itself is considered to be of little importance – only 2% who went overseas, and 5% who went home or stayed in the UK believe it to be the most important factor to their employer.

Table 4.2.21 - Perceptions of most important factor to current employer for 2008 and 2010 graduates by level of study

What was most important to your employer?	Overall		UG		PGT		PGR	
	2010 (1,766)	2008 (1,563)	2010 (424)	2008 (398)	2010 (1,193)	2008 (1,031)	2010 (149)	2008 (134)
A qualification from a university/college in the UK	18%	18%	17%	20%	19%	17%	16%	15%
A qualification from my university	5%	4%	4%	4%	5%	3%	5%	8%
The subject(s) studied	32%	32%	29%	32%	33%	33%	35%	27%
The level of study	30%	32%	30%	28%	28%	33%	38%	41%
Don't know	15%	14%	19%	16%	15%	14%	6%	9%

38% (41% of 2008 cohort) of the PGRs consider the level of study the most important to their employer, which is statistically significantly higher than 28% (33% of 2008 cohort) of PGTs who responded similarly (table 4.2.21). The importance of the university remains at approximately 5% for both cohorts and all three levels of study (with the exception of 2008 PGR graduates where 8% think the qualification from their university is most important to their employer).

Table 4.2.22a - Perceptions of most important factor to current employer for 2010 graduates by nationality

What was most important to your employer?	Overall	China	India	USA	Malaysia	Nigeria
	2010 (884)	2010 (258)	2010 (179)	2010 (89)*	2010 (84)*	2010 (70)*
A qualification from a university/college in the UK	21%	29%	23%	13%	23%	16%
A qualification from my university	6%	9%	7%	1%	2%	7%
The subject(s) studied	37%	26%	38%	53%	37%	49%
The level of study	37%	36%	32%	33%	38%	29%

*Number of responses is below 100

Table 4.2.22b - Perceptions of most important factor to current employer for 2008 graduates by nationality

What was most important to your employer?	Overall	China	India	USA	Malaysia	Nigeria
	2008 (785)	2008 (154)	2008 (144)	2008 (87)*	2008 (98)*	2008 (66)*
A qualification from a university/college in the UK	20%	29%	17%	11%	22%	18%
A qualification from my university	5%	6%	6%	1%	0%	8%
The subject(s) studied	38%	31%	39%	38%	41%	41%
The level of study	37%	34%	38%	49%	37%	33%

*Number of responses is below 100

Although the base numbers tend to be low after breaking down the responses by nationalities (table 4.2.22), perceptions of the most important factor to their current employer appears to be fairly consistent across the top five nationalities.

4.3 Further study

Study circumstances

Overall, the 2010 cohort were more likely to be involved in full-time studying, training or academic research on the day of the survey compared to the 2008 cohort (24% and 17% respectively).

Table 4.3.1 - Study circumstances of 2008 and 2010 graduates by study level

Study circumstances on survey date	Overall		UG		PGT		PGR	
	2010 (4,812)	2008 (2,080)	2010 (1,255)	2008 (548)	2010 (2,609)	2008 (1,367)	2010 (948)	2008 (165)
Involved in full-time study, training or academic research	24%	17%	44%	16%	13%	15%	30%	40%
Involved in part-time study, training or academic research	7%	9%	9%	13%	6%	7%	7%	6%
Distance learning	1%	2%	1%	4%	1%	2%	<0.5%	4%
Not involved in study, training or academic research	68%	72%	47%	67%	80%	76%	63%	50%

The largest group involved in full-time study are the 2010 UG graduates (44%) compared to only 16% of the 2008 cohort (table 4.3.1). The higher proportion of UG recent graduates who are back in full-time study may be a reflection on the poor economic conditions and high unemployment rates driving graduates back to education. 67% of the 2008 UG cohort were not involved in any further study, training or academic research on the date of the survey. The high percentage of PGR graduates from both cohorts suggest that PGR graduate respondents may have regarded their academic research and study as the same and therefore the study percentage for PGR graduates may potentially be conflated.

Table 4.3.2 - Study circumstances of 2008 and 2010 graduates by location

Study circumstances on survey date	Overall		Stayed in UK		Went home		Went overseas	
	2010	2008	2010	2008	2010	2008	2010	2008
	(2,557)	(1,632)	(569)	(272)	(1,738)	(1,163)	(250)	(197)
Involved in full-time study, training or academic research	11%	12%	10%	13%	10%	11%	14%	17%
Involved in part-time study, training or academic research	8%	9%	9%	9%	8%	9%	6%	9%
Distance learning	1%	3%	1%	2%	1%	3%	<0.5%	3%
Not involved in study, training or academic research	80%	76%	80%	76%	80%	77%	80%	72%

17% of the 2008 graduates who are elsewhere overseas were involved in full-time study, training or academic research at the time of the study compared to just 14% of 2010 graduates (table 4.3.2). However, most graduates from both cohorts are not involved in study, training, or academic research.

81% of Indian and Taiwanese students who graduated in 2010 were not involved in study, training or academic research (table 4.3.3). This is in contrast to 40% of American 2010 graduates who are still involved in full-time study, training or academic research at the time of the survey. Part-time studying, training or academic research was more popular with graduates from Hong Kong, and Pakistan, compared to other nationalities.

Table 4.3.3a - Study circumstances of 2010 graduates by nationality

Study circumstances on survey date	Overall	China	India	USA	Malaysia	Nigeria	Canada	Pakistan	Hong Kong	Taiwan	Singapore
	2010 (4,812)	2010 (932)	2010 (695)	2010 (522)	2010 (208)	2010 (204)	2010 (158)	2010 (138)	2010 (142)	2010 (116)	2010 (102)
Involved in full-time study, training or academic research	24%	28%	14%	40%	25%	12%	32%	14%	19%	15%	27%
Involved in part-time study, training or academic research	7%	8%	5%	4%	7%	9%	4%	10%	13%	3%	7%
Distance learning	1%	1%	1%	<0.5%	1%	1%	1%	0%	2%	1%	1%
Not involved in study, training or academic research	68%	63%	81%	56%	67%	78%	63%	76%	65%	81%	65%

Table 4.3.3b - Study circumstances of 2008 graduates by nationality

Study circumstances on survey date	Overall	China	India	USA	Malaysia	Nigeria	Canada	Pakistan	Hong Kong	Taiwan	Singapore
	2008 (2,080)	2008 (221)	2008 (244)	2008 (151)	2008 (147)	2008 (119)	2008 (71)*	2008 (116)	2008 (91)*	2008 (60)*	2008 (28)**
Involved in full-time study, training or academic research	17%	12%	12%	15%	14%	17%	15%	14%	11%	22%	25%
Involved in part-time study, training or academic research	9%	8%	7%	9%	7%	6%	4%	10%	20%	<0.5%	7%
Distance learning	3%	1%	4%	1%	1%	3%	6%	1%	2%	2%	7%
Not involved in study, training or academic research	72%	78%	78%	75%	78%	75%	75%	75%	67%	77%	61%

*Number of responses is below 100

**Number of responses is below 50

Qualifications

When asked to describe the qualification they were aiming for on 18th April, 2011, 33% of 2010 graduates were seeking to obtain a taught higher degree. This is statistically significantly higher than 20% of graduates from 2008 who were seeking to attain the same degree.

Table 4.3.4 - Qualifications aimed for by 2008 and 2010 graduates involved in further study, training/research on survey date by original study level

Qualification type	Overall		UG		PGT		PGR	
	2010 (988)	2008 (459)	2010 (480)	2008 (113)	2010 (411)	2008 (271)	2010 (97)*	2008 (55)**
Higher degree, mainly by research (PhD, DPhil, MPhil etc.)	25%	36%	7%	10%	42%	51%	44%	25%
Higher degree, mainly by taught course (MA, MSc etc.)	33%	20%	52%	40%	18%	13%	6%	2%
Postgraduate diploma or certificate (including PGCE)	4%	4%	5%	7%	2%	3%	2%	5%
First degree (BA, BSc etc.)	8%	3%	16%	6%	<0.5%	1%	<0.5%	2%
Other diploma or certificate	3%	5%	2%	6%	4%	3%	2%	7%
Professional qualification, e.g. Accountancy	12%	13%	12%	22%	14%	10%	7%	4%
Other qualification	4%	4%	2%	4%	6%	4%	2%	5%
Not aiming for a qualification	11%	17%	3%	6%	14%	15%	36%	49%

*Number of responses is below 100

**Number of responses is below 50

Over half (51%) of the 2008 PGT graduates were studying towards a higher research degree on the day of survey, compared to just 42% from the 2010 cohort (table 4.3.4). 40% of UG graduates from 2008 who were studying, training or researching on the survey date were studying for a taught higher degree whilst a further 10% were studying for a research postgraduate qualification. 22% were studying for a professional qualification e.g. Accountancy; substantially larger numbers compared with PGT and PGR graduates. 49% of PGR graduates from 2008 who claimed that they were involved in further, study or training stated that they

were not aiming for a particular qualification. This is statistically significantly higher than the 36% of PGR graduates for the 2010 cohort.

Examining where graduates went for their further qualifications (table 4.3.5), 40% of the 2008 graduates who were elsewhere overseas at the time of the survey were studying towards a higher degree (mainly research) compared to only 29% of the 2010 cohort. Of the 2008 graduates who returned home further to obtaining their degree, one quarter were studying towards a research degree and just over a fifth (21%) were studying towards a taught higher degree. 2010 graduates who returned home were more likely to be involved in a first degree (14%) than 2008 graduates (3%). 41% of the 2010 graduates who are elsewhere overseas were engaged in further study but not aiming for a qualification at the time of the survey, this is statistically significantly larger than the 13% of 2008 graduates. The base numbers when broken down by nationality are too low to assess any meaningful differences.

Table 4.3.5 - Qualifications aimed for by 2008 and 2010 graduates involved in further study, training/research on survey date by location

Study circumstances on survey date	Overall		Stayed in UK		Went home		Went overseas	
	2010 (402)	2008 (310)	2010 (98)	2008 (57)	2010 (263)	2008 (206)	2010 (41)**	2008 (47)**
Higher degree, mainly by research (PhD, DPhil, MPhil etc.)	20%	26%	22%	18%	17%	25%	29%	40%
Higher degree, mainly by taught course (MA, MSc etc.)	15%	19%	14%	19%	17%	21%	10%	13%
Postgraduate diploma or certificate (including PGCE)	3%	5%	5%	14%	3%	3%	<0.5%	<0.5%
First degree (BA, BSc etc.)	9%	3%	<0.5%	2%	14%	3%	<0.5%	<0.5%
Other diploma or certificate	5%	5%	5%	0%	6%	6%	<0.5%	11%
Professional qualification, e.g. Accountancy	17%	15%	28%	14%	1%	14%	15%	21%
Other qualification	6%	5%	5%	7%	3%	5%	5%	2%
Not aiming for a qualification	25%	22%	20%	26%	24%	23%	41%	13%

*Number of responses is below 100

**Number of responses is below 50

Place of further study, training or research

Overall, the majority of international graduates chose to return home or travel to a different country for their further studies or training/research for both cohorts (table 4.3.6). Over one third of graduates from 2010 do remain in the UK however, and this is seen mainly in graduates with an undergraduate degree. Unfortunately the base numbers are quite low when broken down by nationality – thus this analysis has been excluded from this report.

Table 4.3.6 - Place of further study, training/research for 2008 and 2010 cohort by study level

Country of further study/training/research	Overall		UG		PGT		PGR	
	2010 (657)	2008 (486)	2010 (320)	2008 (139)	2010 (279)	2008 (286)	2010 (58)*	2008 (61)*
Stayed in the UK	41%	32%	46%	29%	37%	35%	29%	25%
Went Home	49%	50%	46%	57%	52%	46%	59%	51%
Other countries	10%	18%	9%	14%	11%	19%	12%	25%

*Number of responses is below 100

**Number of responses is below 50

Further study motivations

As with the 2008 cohort, graduates considering further study, research or training were most motivated by developing a broader or more specialist range of skills or knowledge, (64%; table 4.3.7). This was particularly true of PGTs (69%) but less true of PGRs (42%). This is also more the case for 2008 graduates (70%) than 2010 graduates (64%).

Table 4.3.7 - Motivations of 2008 and 2010 graduates for undertaking further study, research/training (multi-choice question) by original study level

Motivation for undertaking further study/training/research	Overall		UG		PGT		PGR	
	2010 (594)	2008 (440)	2010 (305)	2008 (131)	2010 (246)	2008 (188)	2010 (43)**	2008 (50)*
To develop a broader or more specialist range of skills or knowledge	64%	70%	64%	67%	69%	73%	42%	62%
To change or improve my career options	40%	42%	44%	48%	35%	43%	33%	24%
Because I was interested in the content of the course	33%	30%	38%	40%	30%	28%	16%	14%
Because I had enjoyed my first course and wanted to continue studying	19%	16%	19%	21%	21%	16%	9%	4%
Because it was a requirement of my employment on 18 April 2011 that I did	14%	16%	13%	16%	13%	15%	26%	20%
I wanted to go on being a student/I wanted to postpone job hunting	11%	5%	14%	2%	6%	7%	9%	2%
I had been unable to find a suitable job	5%	7%	4%	7%	5%	8%	9%	4%
Other	9%	7%	10%	4%	5%	7%	26%	18%

*Number of responses is below 100

**Number of responses is below 50

The base numbers for responses at the nationality level are too small to be meaningful and therefore have not been reported here.

4.4 Visas and time in UK

Visa application

Graduates that were working in the UK on the survey date were asked how long they planned to remain and the type of visa applied for if relevant (table 4.4.1). Based on the results in this report, of the 86% of recent graduates who are working and/or studying, 64% have returned to their home country, 26% have remained in the UK, and 9% have gone elsewhere overseas. For the 95% of 2008 graduates who are studying and/or working, 67% have returned home, 20% have remained in the UK, and 13% are elsewhere overseas.

Table 4.4.1 - Visa applied for to extend stay in the UK immediately after completion of studies by study level

Visa applied for	Overall		UG		PGT		PGR	
	2010 (2,248)	2008 (1,601)	2010 (577)	2008 (397)	2010 (1,528)	2008 (1,086)	2010 (143)	2008 (118)
Yes	42%	46%	46%	45%	40%	47%	45%	45%
No	55%	52%	50%	52%	58%	51%	54%	54%
I don't know	3%	2%	4%	3%	2%	2%	1%	1%

When compared to the 2008 cohort, graduates from 2010 had a smaller proportion of leavers who applied for a visa to extend their stay in the UK immediately after completing their course of study. The overall difference in visa applications is mostly due to PGTs, where a 7% percentage difference is evident (47% vs. 40%). Students at this level were also the least likely overall to make a visa application immediately after completing their course (40% vs. 45% for PGR and 46% for UG).

Recent graduates from Nigeria, India, and Malaysia were the most likely to have applied for a visa to extend their stay (table 4.4.2). For graduates who are in their 3rd year out, those from China, India, and Nigeria are the most likely to have applied for a visa to extend their stay. The types of visas that they applied for, is discussed in the section below (“Visa type”), with reference to table 4.4.4.

Visa type

Of those graduates who did apply for a visa following their studies, the most commonly held visa amongst undergraduates was a Student Visa (Main applicant), applied for by 22% of 2010 graduates (table 4.4.3). This was not the case for 2008 graduates where the Work Visa (Main applicant) was the most commonly held visa amongst undergraduates. This was applied for by 15% of graduates of 2008 but by only 12% in 2010 as presumably a higher percentage of these graduates are looking to stay for further study. The most common type of visa applied for by postgraduates (both research and taught) was a Work Visa (Main applicant) with 15% of PGR and 23% of PGT applying for this type of visa. This pattern is similar to that of 2008 for PGTs but whilst Work Visa (Main applicant) is still the most common visa amongst PGRs, it was less popular for 2008 graduates whilst applications for Student Visa (Main applicant) were greater by 3%.

Table 4.4.2a - Visa applied for to extend stay in the UK immediately after completion of studies for 2010 graduates by nationality

	China	India	USA	Malaysia	Nigeria
Visa Application	2010	2010	2010	2010	2010
	(387)	(340)	(178)	(118)	(125)
Yes	43%	57%	31%	46%	59%
No	53%	41%	67%	51%	39%
I don't know	4%	2%	2%	3%	2%

Table 4.4.2b - Visa applied for to extend stay in the UK immediately after completion of studies by 2008 graduates by nationality

	China	India	USA	Malaysia	Nigeria
Visa Application	2008	2008	2008	2008	2008
	(167)	(195)	(131)	(110)	(94)*
Yes	58%	63%	33%	38%	69%
No	40%	35%	66%	61%	30%
I don't know	2%	2%	1%	1%	1%

*Number of responses is below 100

Table 4.4.3 - Visa type applied for to extend stay in the UK immediately after completion of studies by study level

Visa type immediately after studies	Overall		UG		PGT		PGR	
	2010 (2,248)	2008 (1,601)	2010 (577)	2008 (397)	2010 (1,528)	2008 (1,086)	2010 (143)	2008 (118)
Did not apply to extend stay in UK	55%	52%	50%	52%	58%	51%	54%	54%
Work Visa (Main applicant)	20%	22%	12%	15%	23%	24%	15%	25%
Student Visa (Main applicant)	13%	10%	22%	11%	9%	9%	9%	6%
Citizenship/Leave to remain	1%	2%	2%	3%	1%	1%	4%	4%
Student Visa (Dependant)	<1%	<1%	1%	0%	1%	1%	1%	0%
Marriage Visa	<1%	<1%	1%	1%	<0.5%	1%	3%	0%
Visitor visa (up to 6 months) with work rights	1%	1%	1%	2%	1%	1%	3%	1%
Work Visa (Dependant)	<0.5%	<0.5%	0%	<0.5%	1%	1%	1%	0%
Other	5%	10%	7%	13%	4%	9%	9%	9%
I don't know	3%	2%	4%	3%	2%	2%	1%	1%

Graduates from Singapore and Taiwan were the least likely to have applied for a visa to work in the UK after their studies were complete (table 4.4.4); 73% and 70% respectively did not apply for a visa to stay in the UK after they completed their studies. Out of the top ten countries, Singapore¹⁴ and Taiwan¹⁵ are the only countries with mandatory national service that require men to serve a period of military training which provides an explanation for the high proportion returning home.

¹⁴ Singapore national service: http://www.contactsingapore.sg/investors/live/residency_and_citizenship/national_service/

¹⁵ Taiwan national service: <http://www.taiwan.gov.tw/ct.asp?xItem=27218&ctNode=1967&mp=1001>

The nationalities most likely to have applied for a Student Visa immediately after completing their studies were Chinese and Malaysian graduates. Students from India and Nigeria were more likely to have applied for a Work Visa. As in 2008, a notably larger percentage of undergraduates applied for a Student Visa (Main applicant) than for either of the postgraduate groups and indicative of the proportion of undergraduates who proceed into postgraduate study in the UK.

By far the most likely visa to be held by graduates of 2010 (69%) and 2010 (60%), who remained in the UK on survey date, was the Work Visa (Main applicant), which was the same as found in 2008.

The proportion of graduates holding the Work Visa (Main applicant) is statistically significantly different between the two cohorts for undergraduates (46% for 2008 and 66% for 2010) and PGTs (64% for 2008 and 74% for 2010). However the opposite is true for PGRs where those holding this visa (70% for 2008 and 49% for 2010) whilst 20% fell into the category of 'other' (unspecified) visa types. For PGRs this finding is less robust due to a small base of respondents (23 in 2008 and 35 in 2010).

Table 4.4.4a - Visa type applied for to extend stay in the UK immediately after completion of studies by 2010 graduates by nationality

Visa Application	China	India	USA	Malaysia	Nigeria
	2010 (387)	2010 (340)	2010 (178)	2010 (118)	2010 (125)
Did not apply to extend stay in UK	53%	41%	67%	51%	39%
Work Visa (Main applicant)	12%	48%	12%	17%	42%
Student Visa (Main applicant)	21%	3%	10%	20%	9%
Citizenship/Leave to remain	1%	1%	3%	0%	1%
Student Visa (Dependant)	1%	0%	1%	2%	0%
Marriage Visa	0%	0%	2%	1%	1%
Visitor visa (up to 6 months) with work rights	3%	0%	0%	0%	1%
Work Visa (Dependant)	1%	1%	0%	0%	1%
Other	4%	4%	3%	7%	5%
I don't know	4%	2%	2%	3%	2%

Table 4.4.4b - Visa type applied for to extend stay in the UK immediately after completion of studies by 2008 graduates by nationality

Visa Application	China	India	USA	Malaysia	Nigeria
	2008 (167)	2008 (195)	2008 (131)	2008 (110)	2008 (94)*
Did not apply to extend stay in UK	40%	35%	66%	61%	30%
Work Visa (Main applicant)	23%	41%	18%	11%	37%
Student Visa (Main applicant)	18%	4%	4%	9%	9%
Citizenship/Leave to remain	3%	1%	2%	1%	1%
Student Visa (Dependant)	1%	0%	1%	0%	0%
Marriage Visa	1%	1%	2%	0%	3%
Visitor visa (up to 6 months) with work rights	1%	1%	1%	4%	1%
Work Visa (Dependant)	1%	1%	1%	0%	2%
Other	10%	15%	5%	14%	16%
I don't know	2%	2%	1%	1%	1%

*Number of responses is below 100

Table 4.4.5 - Visa type held by 2008 and 2010 graduates in the UK on survey date by study level

Visa type held on survey date	Overall		UG		PGT		PGR	
	2010 (281)	2008 (242)	2010 (68)*	2008 (68)*	2010 (178)	2008 (151)	2010 (35)**	2008 (23)**
Work Visa (Main applicant)	69%	60%	66%	46%	74%	64%	49%	70%
Student Visa (Main applicant)	7%	4%	6%	6%	7%	3%	9%	9%
Citizenship/Leave to Remain	8%	12%	10%	15%	6%	9%	14%	17%
Work Visa (Dependant)	1%	2%	1%	4%	1%	2%	3%	0%
Marriage Visa	3%	6%	6%	7%	2%	6%	6%	4%
Student Visa (Dependant)	<0.5%	<0.5%	0%	0%	1%	1%	0%	0%
I did not work in the UK after I completed my studies	<0.5%	0%	0%	0%	<0.5%	0%	0%	0%
Other	10%	14%	10%	18%	8%	15%	20%	0%
I don't know	<0.5%	2%	0%	4%	1%	1%	0%	0%

*Number of responses is below 100

**Number of responses is below 50

There is an overall difference in graduates having citizenship/leave to remain (12% of 2008 graduates and 8% of 2010 graduates; table 4.4.5). The difference is apparent at all study levels, with the most notable being amongst 2008 undergraduates where the proportion having citizenship/leave to remain is at 15% but is 10% amongst 2010 graduates. This perhaps reflects the changes to immigration policy and tightening of requirements for permanent residency.

Visa satisfaction

Graduates were asked how satisfied or dissatisfied they were with the visa application process overall irrespective of the outcome of their application. Overall, 2010 graduates indicated reasonably high levels of satisfaction with the visa application process and similar levels overall as in 2008 (table 4.4.6). 78% of this cohort indicated that they were satisfied or very satisfied with the process. When considered by study level, undergraduates were the most satisfied but the level of satisfaction was similar across all levels of study (79% UG, 78% PGT, and 76% PGR).

Table 4.4.6 - 2008 and 2010 cohort satisfaction with the UK visa system by study level

Satisfaction with UK visa system	Overall		UG		PGT		PGR	
	2010 (2,060)	2008 (1,312)	2010 (502)	2008 (306)	2010 (1,422)	2008 (908)	2010 (136)	2008 (98)*
Very satisfied	17%	19%	16%	15%	17%	20%	21%	19%
Satisfied	61%	58%	63%	61%	61%	59%	55%	49%
Dissatisfied	16%	15%	15%	13%	16%	15%	18%	21%
Very dissatisfied	6%	8%	5%	11%	6%	6%	7%	10%

*Number of responses is below 100

According to table 4.4.7, the graduates in 2010 who indicated highest levels of satisfaction with the visa system were from India (85% satisfied or very satisfied) whilst the least satisfied were from the USA (71% satisfied or very satisfied). The base number for other nationalities is very small, so generalisation of results should be cautioned.

Table 4.4.7a - 2010 cohort satisfaction with the UK visa system by nationality

Satisfaction with UK visa system	China	India	USA	Malaysia	Nigeria
	2010	2010	2010	2010	2010
	(384)	(326)	(155)	(107)	(114)
Very satisfied	13%	23%	15%	11%	18%
Satisfied	67%	62%	56%	69%	62%
Dissatisfied	18%	11%	20%	13%	14%
Very dissatisfied	2%	4%	9%	7%	5%

Table 4.4.7b - 2008 cohort satisfaction with the UK visa system by nationality

Satisfaction with UK visa system	China	India	USA	Malaysia	Nigeria
	2008	2008	2008	2008	2008
	(165)	(175)	(89)*	(92)*	(91)*
Very satisfied	16%	23%	13%	12%	29%
Satisfied	63%	51%	57%	61%	46%
Dissatisfied	14%	19%	16%	21%	15%
Very dissatisfied	7%	7%	13%	7%	10%

Plans to stay in the UK

When compared to 2008, the 2010 cohort of working graduates appear to be less intent on staying for a long period of time in the UK (table 4.4.8). Approximately 35% of graduates from the 2010 cohort, plan to stay for two years or less, which is statistically significantly higher than graduates from the 2008 cohort (approximately 11%). This finding is likely to be related to the availability of the Post-Study Work visa which allows international graduates to apply to remain in the UK for up to two years after graduation and may in part be due to graduates of the 2008 cohort having left already. In addition, the proportion of students planning to stay permanently differs by 11%. 23% of graduates of the 2008 cohort plan to stay permanently, whilst only 12% of graduates of the 2010 cohort are planning to do so. These findings are remarkably similar to those from last year's survey.

UG graduates are the most likely to be intending to remain permanently in the UK after completing their studies (table 4.4.9). 15% of the UG 2010 cohort intend to remain (and 21% of the 2008 cohort) compared with 14% for PGR graduates and 10% for PGT graduates of the 2010 cohort. Analysis by nationality is difficult due to the very small base of respondents and therefore the results are not shown here.

Table 4.4.8 - Length of time for 2007, 2008, 2009 and 2010 working graduates plan to remain

Length of time plan to remain in UK	Overall (2 nd wave)		Overall (1 st wave)	
	2010 (299)	2008 (250)	2009 (377)	2007 (340)
Less than 1 month	1%	<0.5%	1%	0%
1 to 2 months	<0.5%	<0.5%	1%	<1%
3 to 4 months	1%	1%	1%	1%
5 to 6 months	3%	<0.5%	1%	1%
7 to 12 months	6%	2%	5%	2%
1 to 2 years	24%	7%	24%	6%
2 to 3 years	8%	4%	5%	8%
3 to 4 years	4%	4%	7%	7%
More than 4 years	11%	17%	10%	15%
Permanently	12%	23%	14%	21%
Don't know	29%	42%	29%	39%

Table 4.4.9 - Length of time for 2008 and 2010 working graduates plan to remain by study level

Length of time plan to remain in UK	Overall		UG		PGT		PGR	
	2010 (299)	2008 (250)	2010 (74)*	2008 (71)*	2010 (189)	2008 (154)	2010 (36)**	2008 (25)**
Less than 1 month	1%	<0.5%	0%	1%	2%	0%	0%	0%
1 to 2 months	<0.5%	<0.5%	0%	0%	1%	0%	0%	0%
3 to 4 months	1%	1%	0%	1%	2%	1%	3%	0%
5 to 6 months	3%	<0.5%	0%	0%	4%	0%	3%	4%
7 to 12 months	6%	2%	7%	3%	7%	2%	0%	0%
1 to 2 years	24%	7%	19%	6%	29%	8%	14%	0%
2 to 3 years	8%	4%	4%	6%	8%	3%	11%	4%
3 to 4 years	4%	4%	7%	1%	3%	4%	3%	8%
More than 4 years	11%	17%	9%	10%	12%	20%	14%	16%
Permanently	12%	23%	15%	21%	10%	24%	14%	24%
Don't know	29%	42%	39%	51%	23%	38%	39%	40%

*Number of responses is below 100;

**Number of responses is below 50

4.5 Reflections of the UK experience

Employment in the UK during or before course

The majority of respondents from the 2010 cohort were not working during or immediately before their course (81%) and, of those that were, were mainly working in an area that was not relevant to their career plans (table 4.5.1). This is same pattern for 2008 graduates, but the proportion of recent graduates from 2010 that were not in any form of employment is statistically significantly greater by 10%.

Table 4.5.1 - 2008 and 2010 graduates' employment in the UK during course or immediately before it by study level

Employment in the UK during or immediately before course	Overall		UG		PGT		PGR	
	2010 (2,458)	2008 (1,728)	2010 (657)	2008 (443)	2010 (1,642)	2008 (1,161)	2010 (159)	2008 (124)
No	81%	71%	79%	73%	82%	71%	72%	59%
Yes – working in programme or placement through course	3%	5%	4%	6%	3%	5%	10%	11%
Yes – working outside course in relevant area to career plans	4%	7%	4%	5%	4%	7%	11%	16%
Yes – working outside course in area not relevant to career plans	12%	16%	13%	16%	12%	17%	8%	14%

Those that went to their home country after finishing their studies are the least likely to have been employed in the UK (86% compared to 79% of those going to another country and 51% of those staying in the UK; table 4.5.2).

Table 4.5.2 - 2008 and 2010 graduates' employment in the UK during course or immediately before it by location

Employment in the UK during or immediately before course	Overall		Stayed in UK		Went home		Another country	
	2010 (1,690)	2008 (1,490)	2010 (299)	2008 (250)	2010 (1,253)	2008 (1,056)	2010 (138)	2008 (184)
No	80%	72%	51%	58%	86%	75%	79%	72%
Yes – working in programme or placement through course	4%	5%	10%	11%	2%	4%	7%	3%
Yes – working outside course in relevant area to career plans	5%	8%	14%	15%	3%	6%	4%	9%
Yes – working outside course in area not relevant to career plans	12%	16%	25%	17%	9%	15%	10%	16%

From the 2010 cohort, Nigerian students are the most likely to have worked during or immediately before their course (Indian students were the most likely from 2008 cohort, at 27%), and table 4.4.4 shows that they are also the most likely to apply for a work visa after completing their studies. In contrast, those from China appear to be the least likely to have worked in the UK during or immediately before their course and are also amongst the least likely to apply for a UK work visa after their studies (see table 4.5.3).

Table 4.5.3a - 2010 graduates' employment in the UK during course or immediately before it by nationality

Employment in the UK during or immediately before course	China	India	USA	Malaysia	Nigeria
	2010 (420)	2010 (351)	2010 (192)	2010 (126)	2010 (138)
No	85%	73%	72%	77%	66%
Yes – working in programme or placement through course	5%	4%	4%	2%	1%
Yes – working outside course in relevant area to career plans	3%	7%	7%	2%	9%
Yes – working outside course in area not relevant to career plans	8%	17%	18%	19%	23%

*Number of responses is below 100

**Number of responses is below 50

Table 4.5.3b - 2008 graduates' employment in the UK during course or immediately before it by nationality

Employment in the UK during or immediately before course	China	India	USA	Malaysia	Nigeria
	2008 (176)	2008 (202)	2008 (132)	2008 (121)	2008 (100)
No	71%	62%	68%	75%	51%
Yes – working in programme or placement through course	7%	3%	2%	6%	7%
Yes – working outside course in relevant area to career plans	7%	8%	10%	6%	15%
Yes – working outside course in area not relevant to career plans	14%	27%	20%	13%	27%

*Number of responses is below 100

**Number of responses is below 50

Motivations to study in the UK

In the case of both the 2008 and 2010 cohorts, UGs are statistically significantly less likely to quote career progression as the motivating factor for choosing their course than both PGTs and PGRs (figure 4.5.1). PGTs were also more likely to highlight changing careers as the motivating factor - significantly more so than both UGs and PGRs from 2010, and significantly more so than UGs from 2008.

In contrast, UGs from both the 2010 and the 2008 cohorts were statistically significantly more likely to highlight the subject matter as the principal reason for selecting their course. UGs were also significantly more likely to answer 'Other Reason' to this question.

Comparing the two cohorts, PGTs from 2010 (60%) were statistically significantly more likely to highlight career progression as the key motivator than their 2008 counterparts (57%). Conversely, PGTs from 2008 (30% vs. 26%) were significantly more likely to have chosen their course on the basis of interest in the subject matter.

Figure 4.5.1 - Motivations to study in the UK for 2008 and 2010 graduates by study level

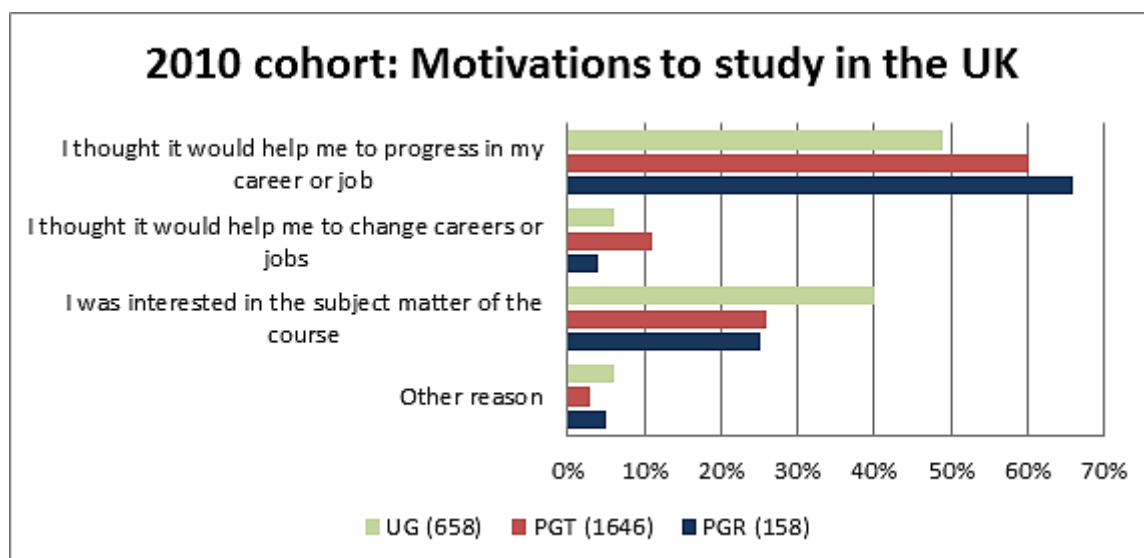

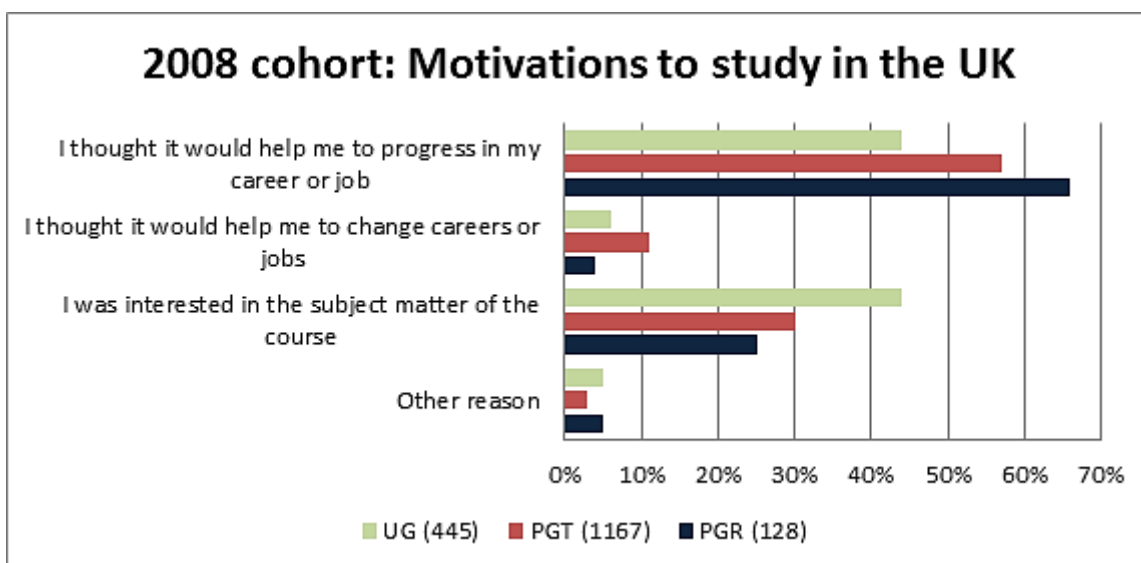

Overall reflections

Overall, graduates from both the 2008 and 2010 cohorts are satisfied with the learning, living, and support experience during their UK studies (table 4.5.4) and perceive that their UK degree was worth the financial investment. Both sets of respondents are least likely to agree that 'being an alumnus of my university means I can command a higher salary'. Table 4.5.5 compares the overall reflections of 2010 graduates with those of international students and UK-domiciled students in 2010 using results from the International Student Barometer^{TM 16} and Student Barometer^{TM 12}. The results are largely similar, with the exception that 2010 graduates responding to the i-GO survey being less happy with the support provided by their university (82%). The National Student Survey, a UK government initiative which surveys final year undergraduate students (irrespective of domicile), indicated that 82% were satisfied overall with the quality of their course. Thus, indications from international students, UK-domiciled students, international graduates, and final year undergraduate students, demonstrate that they are satisfied with their higher education experience.

Amongst UGs, there are some large differences between respondents from 2010 and 2008: in the 4 questions related to career progression and higher salaries, the 2008 group was at least 5% less satisfied than the 2010 cohort. In questions related to their specific university, the value of a UG degree appears to diminish considerably over time both in terms of career progression (58% amongst 2010

¹⁶ The International Student Barometer (ISB) and the Student Barometer (SB) are global benchmarking studies of expectations and experiences of students in HEIs in the UK and around the world. The ISB surveys international students, and the SB in the UK surveys UK-domiciled students. The results used here are taken from responses from international students studying in UK HEIs in 2010.

respondents vs. 46% from 2008) and commanding higher salaries (39% from 2010 vs. 26% from 2008). This lower level of satisfaction is mirrored in the assessment of financial worth (84% from 2010 vs. 81% from the 2008 cohort) and support from the university (84%, 2010 vs. 79%, 2008), but not in reflections of the learning or living experience in the UK.

Similar inclinations amongst PGT respondents are also noticeable, particularly when assessing the ability to progress more quickly with their career. For instance, 78% of the 2010 cohort agreed that a UK degree allowed career progression relative to 72% amongst the 2008 cohort. Amongst PGRs, a large contrast occurred between those believing that a UK degree allowed them to command a higher salary: from 2010 respondents the figure agreeing is 51% and only 43% amongst the 2008 cohort. Therefore a general theme emerges: the value of UK qualifications (both in terms of career progression and salary level) at all study levels is rated more highly amongst the 2010 cohort than the 2008 respondents.

The most popular destination for graduates was their home country – 74% of the 2010 cohort and 72% of the 2008 cohort. Staying in the UK was equally likely for the both cohorts, but represented a small percentage of the total sample – in the region of 10-15%. The number now working elsewhere overseas is higher amongst the 2008 cohort, which is likely indicative of labour mobility over time, rather than immediately after completing a UK qualification.

Some interesting differences emerge between those returning home and those that remain in the UK – responses from those working elsewhere overseas tend to follow a similar pattern to those returning home, and these differences are detailed in the following sections.

Table 4.5.4 - 2008 and 2010 graduate reflections of the UK (% agree and strongly agree with statement) by study level

Reflections of UK experience	Overall (4,036)		UG (1,040)		PGT (2719)		PGR (277)	
	2010 (2,359)	2008 (1,677)	2010 (618)	2008 (422)	2010 (1,586)	2008 (1,133)	2010 (155)	2008 (122)
My UK degree was worth the financial investment	80%	83%	84%	81%	78%	82%	88%	92%
Having a qualification from the UK means I can progress more quickly in my career	76%	71%	73%	68%	78%	72%	75%	73%
Being an alumnus of my university means I can progress more quickly in my career	57%	50%	58%	46%	57%	51%	54%	54%
Having a qualification from the UK means I can command a higher salary	52%	51%	54%	45%	57%	53%	51%	43%
Being an alumnus of my university means I can command a higher salary	38%	33%	39%	26%	39%	36%	31%	31%
I am satisfied with the learning experience at my university	88%	91%	88%	91%	88%	92%	87%	89%
I am satisfied with the living experience at my university	88%	88%	86%	87%	89%	89%	85%	86%
I am happy with the support provided by my university	82%	82%	84%	79%	81%	82%	77%	86%
I felt welcome in the UK	86%	87%	86%	87%	86%	87%	86%	85%

Table 4.5.5 - 2010 graduate reflections of the UK compared to results from the International Student Barometer™ and the Student Barometer™ run in the UK

	2010 i-GO (2,359)	2010 ISB (32,617)	2010 SB (23,730)
My UK degree was worth the financial investment	80%	77%	85%
I am satisfied with the learning experience at my university	88%	85%	87%
I am satisfied with the living experience at my university	88%	86%	89%
I am happy with the support provided by my university	82%	89%	90%

Financial Investment

Amongst the 2010 cohort, PGRs and UGs are statistically significantly more likely to consider the degree worthwhile than PGTs (3.1 mean score vs. 3.0 vs. 2.9; 88% agree/strongly agree vs. 84% vs. 78%). The postgraduate cohort (both PGTs and PGRs) from 2008 are more likely to consider a UK degree financially worthwhile than the 2010 cohort; although the opposite is the case amongst the undergraduate respondents (84% from 2010 agree/strongly agree vs. 81% from 2008).

It is also interesting to note the greater percentage of PGTs agreeing/strongly agreeing with the statement from the 2008 cohort (82% vs. 78% amongst 2010 respondents). This may either indicate that PGTs are now less likely to consider their UK degree financially worthwhile, or that the value of the degree becomes more evident a couple of years after graduation. There is a statistically significantly higher percentage of PGTs from 2008 that strongly agreed with the statement (27% vs. 21% from the 2010 cohort).

Those who returned home (in both the 2010 and 2008 cohorts) were statistically significantly more likely to consider a UK degree worth the financial investment than those who stayed in the UK. Those who return home will be more likely to be competing in the job market against non-UK graduates, so these graduates are perhaps more likely to see the direct and instant benefit from their investment.

For the 2010 cohort, some nationalities are clearly less positive than others (table 4.5.7) and, amongst the top 10 featured here, respondents from India, USA, Canada, Hong Kong and Taiwan tend to provide lower agreement / satisfaction scores in their reflections of UK study. Chinese respondents, on the other hand, are generally far more positive.

It can be seen that Indian and Taiwanese students are least likely to believe a UK degree was worth the investment. On the other hand, Chinese and Singaporeans are most positive. Interestingly, given some of the lower satisfaction scores on other measures, American and Canadian respondents also more likely than average to believe a UK degree was worth the investment. The response does seem to show a positive correlation between standard of living and level of agreement, although Taiwan appears to be an exception to this rule.

On whether the degree was financially worthwhile, the agreement figure of 69% for Indian graduates amongst the 2008 cohort seems low relative to the mean, but it is 8% higher than the rate returned for the 2010 cohort (table 4.5.7). As has been illustrated before, it is not immediately clear whether this should be viewed positively (i.e. as a sign that perceptions of value improve over time) or negatively (i.e. that more recent Indian respondents are becoming significantly less likely to feel a UK degree is financially worthwhile). Nigerian graduates demonstrate the same pattern (89% agreement amongst the 2008 cohort, 80% from 2010); conversely, US respondents from the 2008 cohort are less likely to consider the investment worthwhile financially (78% vs. 84%).

Table 4.5.6 - 2008 and 2010 graduate reflections of the UK (% agree and strongly agree with statement) by location

Reflections of UK experience	Overall (4,036) ¹⁷		Stayed in UK (525)		Went Home (2,244)		Working overseas (310)	
	2010 (2,359)	2008 (1,677)	2010 (290)	2008 (235)	2010 (1208)	2008 (1036)	2010 (135)	2008 (175)
My UK degree was worth the financial investment	80%	83%	77%	80%	86%	85%	83%	85%
Having a qualification from the UK means I can progress more quickly in my career	76%	71%	79%	72%	79%	73%	72%	74%
Being an alumnus of my university means I can progress more quickly in my career	57%	50%	59%	43%	60%	53%	60%	53%
Having a qualification from the UK means I can command a higher salary	52%	51%	61%	52%	57%	51%	59%	55%
Being an alumnus of my university means I can command a higher salary	38%	33%	38%	23%	40%	35%	40%	35%
I am satisfied with the learning experience at my university	88%	91%	86%	88%	91%	93%	89%	93%
I am satisfied with the living experience at my university	88%	88%	91%	91%	89%	88%	86%	89%
I am happy with the support provided by my university	82%	82%	82%	82%	85%	83%	81%	86%
I felt welcome in the UK	86%	87%	86%	90%	89%	88%	86%	84%

¹⁷ The categories "Stayed in the UK", "Went Home" and "Working Overseas" were derived from responses to location/address of current employer. In some cases, it was not possible to determine location, so this explains the difference between the overall base number and the combined total of the three categories. It is nonetheless interesting to note that far more responses from the 2010 cohort were lost in this manner.

Table 4.5.7a - 2010 graduate reflections of the UK (%agree and strongly agree with statement) by nationality

Reflections of UK experience	Overall	China	India	USA	Malaysia	Nigeria	Canada	Pakistan	Hong Kong	Taiwan	Singapore
	2010 (2,359)	2010 (407)	2010 (337)	2010 (181)	2010 (121)	2010 (129)	2010 (64)*	2010 (80)*	2010 (100)	2010 (68)*	2010 (27)**
My UK degree was worth the financial investment	80%	86%	61%	84%	82%	80%	84%	73%	82%	69%	85%
Having a qualification from the UK means I can progress more quickly in my career	77%	81%	70%	54%	79%	76%	61%	83%	71%	75%	70%
Being an alumnus of my university means I can progress more quickly in my career	58%	64%	54%	44%	59%	61%	47%	57%	42%	57%	48%
Having a qualification from the UK means I can command a higher salary	56%	58%	53%	39%	51%	53%	34%	65%	52%	58%	48%
Being an alumnus of my university means I can command a higher salary	39%	44%	36%	28%	34%	37%	24%	42%	31%	37%	33%
I am satisfied with the learning experience at my university	88%	92%	83%	88%	89%	88%	87%	80%	85%	87%	96%
I am satisfied with the living experience at my university	88%	91%	88%	82%	92%	92%	89%	87%	85%	86%	96%
I am happy with the support provided by my university	82%	88%	77%	68%	88%	87%	83%	87%	80%	82%	85%
I felt welcome in the UK	86%	87%	88%	91%	83%	81%	89%	91%	74%	78%	96%

*Number of responses is below 100

**Number of responses is below 50

Table 4.5.7b - 2008 graduate reflections of the UK (%agree and strongly agree with statement) by nationality

Reflections of UK experience	Overall	China	India	USA	Malaysia	Nigeria	Canada	Pakistan	Hong Kong	Taiwan	Singapore
	2008 (1,677)	2008 (172)	2008 (193)	2008 (128)	2008 (122)	2008 (96)*	2008 (66)**	2008 (93)*	2008 (67)*	2008 (50)*	2008 (27)**
My UK degree was worth the financial investment	83%	85%	69%	78%	86%	89%	81%	73%	84%	72%	85%
Having a qualification from the UK means I can progress more quickly in my career	71%	74%	57%	45%	69%	81%	58%	74%	70%	76%	63%
Being an alumnus of my university means I can progress more quickly in my career	51%	56%	38%	35%	47%	56%	38%	51%	46%	46%	44%
Having a qualification from the UK means I can command a higher salary	51%	54%	42%	18%	40%	58%	31%	64%	60%	52%	48%
Being an alumnus of my university means I can command a higher salary	32%	32%	24%	16%	23%	40%	16%	46%	34%	32%	33%
I am satisfied with the learning experience at my university	91%	95%	86%	80%	94%	94%	86%	87%	88%	94%	89%
I am satisfied with the living experience at my university	88%	91%	89%	87%	94%	90%	79%	88%	81%	86%	85%
I am happy with the support provided by my university	82%	89%	73%	66%	84%	82%	84%	87%	72%	82%	81%
I felt welcome in the UK	87%	90%	86%	89%	91%	81%	89%	85%	83%	84%	80%

*Number of responses is below 100

**Number of responses is below 50

Career Progression and Commanding a Higher Salary

Graduates from different levels of study are more or less in agreement with each other about the value of their degree from the UK and their institution in commanding a higher salary or helping their career progression.

However, comparing respondent results from 2010 with those from 2008 demonstrates that both 2010 UGs and PGTs are significantly more likely to agree with the statement than those from 2008 (e.g. UGs, 50% of 2010 respondents, 41% of those from 2008), and significantly less likely to select that they disagree. This is either an indication of growing satisfaction with the career progression possibilities generated by degrees at specific UK universities, or alternatively lower satisfaction amongst older graduates, based upon subsequent experience.

In a number of areas, international graduates remaining in the UK are less positive than those that had returned home (table 4.5.6). This is noticeable amongst the 2008 cohort when considering the effect of being an alumnus of their university on both career progression and salary level. Comparing directly against those that returned home (53% vs. 43% agreement on career progression; 35% vs. 23% agreement on higher salary) shows significant differences – and indicate that the perceived value of degrees from their specific institution diminishes not only over time but also depending upon destination.

For the 2010 cohort, Pakistani students are most positive about the effect of a UK degree upon their career progression prospects (table 4.5.7). Whilst American and Canadian students are least positive, over half still agree that a UK degree would allow quicker career progression. American and Canadian graduates are also least likely to believe their specific university helped their career progression. Less than 50% of respondents from Hong Kong and Singapore also agree with this point.

Commanding a higher salary

Amongst the 2008 cohort (table 4.5.4), PGTs are the most likely to agree or strongly agree with the statement 'Having a qualification from the UK means I can command a higher salary' (53% PGTs vs. 45% UGs vs. 43% PGRs). A similar pattern, though not statistically significant, emerges from 2010 respondents as well. American students are even more negative amongst the 2008 cohort about career progression and especially higher salaries – here, agreement rates of only 18% and 16% are reported for American graduates. 2008 graduates from Nigeria and Hong Kong are the only nationalities to increasingly believe their career progression and salaries have been positively affected by study in the UK.

Amongst UGs, statistically significant differences emerge between the 2010 and 2008 respondent sets. In terms of the average level of agreement with the UK statement, the 2010 cohort is significantly higher (rounded to 2.6 for 2010 and 2.5 for 2008, based upon a 1-4 scale with 4 being Strongly Agree). The general level of

agreement ('Agree' and 'Strongly Agree') with the statement is also significantly higher amongst the 2010 cohort (54% vs. 45%), and the percentage selecting 'Disagree' significantly lower (39% vs. 47% amongst the 2008 cohort).

In general, there was the lowest level of agreement with the statement 'Being an alumnus of university means I can command a higher salary'. In the 2008 cohort, the average level of agreement was highest for PGTs, although this was only significantly higher than the equivalent UG figure. Within the 2010 cohort, a similar level of agreement existed between UGs and PGTs.

Looking specifically at figures for UGs, the 2010 cohort are statistically significantly more likely to agree than the 2008 cohort (35% vs. 23% from 2008). This may be an indication that UGs from 2008 have spent longer in the workplace and that opinions are revised over time. The same tendency exists at other study levels, but the differences with UGs are not significant.

It is perhaps not surprising that American respondents are least likely to agree, given higher average prevailing salaries in this country. The percentage of respondents from the US and Canada agreeing is low (between 24% and 39%) and well under the mean figures.

Learning Experience

There are very high levels of agreement with the statement, 'I am satisfied with the learning experience at university': for each of the cross-breaks of study level and cohort year, the mean satisfaction score is 3.2. Strong agreement with the statement is highest amongst postgraduates (PGTs and PGRs), although the differences are not significant.

At the PGT level, there is higher satisfaction with the learning experience amongst the 2008 cohort. This may either be indicative of declining levels of satisfaction with the learning experience or an indication that reflections of the learning experience improve over time.

Whilst satisfaction levels are high amongst all graduates, there is a statistically significantly higher satisfaction rate amongst those that returned home (relative to those that stayed in the UK). This is true of both the 2008 and 2010 cohorts. Interestingly, given the low levels of agreement with career progression and salary level questions, slightly higher levels of satisfaction are obtained from the 2008 cohort than more recent graduates.

Satisfaction with the learning experience is widespread amongst the 2010 graduates (table 4.5.6) – even though Pakistani respondents report lowest satisfaction, four-fifths of graduates still agreed with the statement. Satisfaction with the learning experience is generally more positive amongst the 2008 cohort, with an average

response rate of 91%. The only nationalities to return lower satisfaction rates over time were Americans and Singaporeans (the latter affected by the low base size).

Living Experience

As with the learning experience, this is broadly even across all study levels and both cohorts. Satisfaction levels are likewise very high.

Amongst the 2010 cohort, PGR satisfaction appears to be slightly lower than at other study levels. PGTs report a significantly higher mean satisfaction score than PGRs, whilst UGs report a significantly higher percentage of those who are highly satisfied ('Strongly Agree') than PGRs.

Satisfaction with the living experience in the 2010 cohort (table 4.5.6) produced consistently high satisfaction scores, a few nationalities reporting rates above 90%. Respondents from the US reported the lowest score at 82%, 6% below the mean. The 2008 American cohort do however report higher levels of satisfaction with the living experience (87%, 2008 vs. 82%), whereas reflections amongst Canadians and Hong Kong graduates from 2008 were much lower amongst the equivalent figures for 2010.

Support from University

Satisfaction levels with support provided by the university are broadly similar amongst the 2008 and 2010 cohorts and are relatively high at around 80% of respondents.

Between the different study levels though, there are some variations in satisfaction levels. For instance, amongst the 2010 cohort, UGs report a significantly higher mean satisfaction score than PGRs. Conversely, amongst the 2008 cohort, the mean satisfaction score for both PGRs and PGTs is significantly higher than for UGs.

Support provided by the university generates a more variable response from international graduates of 2010 (table 4.5.6): in particular, American respondents seem less significantly satisfied with the level of support offered, with a satisfaction score of 68%, 14% below the mean. This is likely to be a symptom of better provision of student and graduate support by American universities. Indian students are also somewhat negative about support for graduates, whilst – on the other hand – respondents from China, Malaysia, Nigeria and Pakistan show much higher rates of satisfaction.

Whilst overall satisfaction with support provided by universities is broadly comparable between the two cohorts, several nationalities did report lower

satisfaction rates amongst 2008 respondents, including India, Malaysia, Nigeria, Hong Kong and Singapore.

UK Welcome

The satisfaction levels recorded for the question 'I felt welcome in the UK' are both high (at 85-87%) and extremely consistent across the cohorts and study levels. No significant differences emerge across the various cross-breaks, indicating a wide-ranging satisfaction amongst the respondent group.

As highlighted in the previous table and section, the 2010 cohort are significantly more likely to agree with statements related to career progression than their 2008 counterparts, whether in regard to the UK or their specific university. A similar difference is evident between 2010 and 2008 perceptions of higher salaries, although more specifically related to their particular university.

2010 graduates from Hong Kong were least likely to be satisfied – at only 74% (table 4.5.6). Respondents from Nigeria and Taiwan also demonstrate lower than average satisfaction rates, whilst US, Pakistani and Singaporean respondents report satisfaction rates above 90%. Several nationalities report higher satisfaction rates by at least 3% amongst the 2008 cohort (China 90% vs. 87%; Malaysia 91% vs. 83%; Hong Kong 83% vs. 74%; and Taiwan 84% vs. 78%); whilst Pakistani (85% vs. 91%) and Singaporean (80% vs. 96%) graduates from 2008 reported felt less welcome.

4.6 Future plans

Table 4.6.1 - Likelihood of 2008 and 2010 graduates to undertake various activities in the next 5 years (multi-choice question) by study level

Future plans	Overall		UG		PGT		PGR	
	2010	2008	2010	2008	2010	2008	2010	2008
Seek short term employment in UK	37% (2,262)	27% (1,624)	39% (590)	29% (407)	37% (1,530)	27% (1,095)	34% (142)	33% (122)
Seek long term employment in UK	44% (2,314)	39% (1,643)	47% (601)	44% (412)	43% (1,555)	37% (1,111)	47% (149)	32% (120)
Undertake further study in UK	49% (2,296)	44% (1,641)	55% (601)	51% (413)	48% (1,550)	43% (1,108)	34% (145)	28% (120)
Visit the UK for holiday/leisure	85% (1,632)	84% (2,298)	85% (596)	84% (410)	84% (1,556)	86% (1,102)	83% (146)	81% (120)
Apply for permanent residence in UK	29% (2,287)	27% (1,635)	32% (587)	30% (406)	27% (1,553)	27% (1,108)	34% (147)	24% (121)

Future plans	Overall		UG		PGT		PGR	
	2010	2008	2010	2008	2010	2008	2010	2008
Develop professional links with organisations in UK	78% (1,800)	76% (1,641)	74% (601)	68% (408)	78% (1,562)	78% (1,113)	92% (152)	79% (120)
Collaborate with UK unis/colleges for academic/research purposes	61% (2,300)	59% (1,642)	55% (592)	45% (410)	60% (1,556)	62% (1,111)	96% (152)	82% (121)
Seek to remain connected with my university	86% (2,319)	86% (1,650)	80% (599)	81% (411)	88% (1,568)	87% (1,119)	91% (152)	87% (120)

Overall, the likelihood of graduates undertaking certain activities in the next five years is not substantially different than the 2008 cohort, with the vast majority (over 85%) seeking to remain connected with their university and a similar proportion considering visiting the UK for leisure purposes (table 4.6.1). Nearly half the graduates from 2010 (44%) are seeking long-term employment in the UK, differing significantly from those who graduated in 2008 (39%).

A smaller percentage would apply for permanent residence in the UK (29% for 2010 graduates and 27% for 2008 graduates) which was highest for 2010 PGRs (34%). Perhaps unsurprisingly, research postgraduates who graduated in 2010 are much more likely than undergraduates or taught postgraduates (and even research postgraduates from 2008) to be considering remaining connected to their university (91%), to collaborate with UK universities or colleges for research purposes (96%) and to develop links with organisations in the UK (92%).

When considering the location of respondents, those who were working in the UK at the time of the research are less likely to be considering applying for permanent residency than the 2008 cohort – 53% stated that it was likely that they would do so, 20% lower than recent 2010 graduates.

Table 4.6.2 - Likelihood of 2008 and 2010 graduates to undertake various activities in the next 5 years (multi-choice question) by location

Future plans	Overall		Working in UK		Went home		Working overseas	
	2010	2008	2010	2008	2010	2008	2010	2008
Seek short term employment in UK	33% (1,552)	26% (1,397)	48% (262)	31% (220)	31% (1,160)	25% (1,006)	26% (130)	28% (171)
Seek long term employment in UK	42% (1,586)	38% (1,415)	79% (276)	83% (230)	34% (1,179)	28% (1,013)	35% (131)	30% (172)
Undertake further study in UK	51% (1,578)	44% (1,413)	50% (277)	51% (231)	53% (1,169)	44% (1010)	41% (132)	37% (172)
Visit UK for holiday/leisure	87% (1,580)	87% (1,407)	73% (266)	73% (213)	90% (1,180)	90% (1,021)	92% (134)	85% (173)
Apply for permanent residence in UK	29% (1,571)	27% (1,409)	53% (276)	73% (226)	23% (1,166)	18% (1,010)	25% (129)	22% (173)
Develop professional links with organisations in UK	79% (1,595)	76% (1,414)	91% (282)	90% (229)	76% (1,183)	73% (1,013)	84% (130)	68% (172)
Collaborate with UK unis /colleges for academic /research purposes	62% (1,587)	58% (1,413)	63% (278)	55% (227)	61% (1,176)	57% (1,015)	67% (133)	63% (171)
Seek to remain connected with my university	88% (1,599)	87% (1,422)	87% (279)	84% (229)	88% (1,187)	88% (1,020)	94% (133)	88% (173)

By country, 2010 graduates from Pakistan and India are the most likely to consider seeking employment in the UK (whether short or long term) in the five years after their course (table 4.6.3a). Taiwanese and Nigerian students are also likely to be considering UK employment. Graduates from Nigeria, Pakistan and India are also notably more likely than their counterparts to want to develop professional links with organisations within the UK.

Chinese and Canadian students are the least likely to seek UK employment, with only around a third considering doing so in the next five years, which is similar for both short and long term positions. Graduates from the USA are the least likely to be considering further study in the UK (29%), and those from Nigeria are the most likely to consider it (69%). Compared to graduates from the other countries considered

here, Canadians are the least likely to be considering application for permanent residency (14% compared to the overall of 29%).

Table 4.6.3a - Likelihood of 2010 graduates to undertake various activities in the next 5 years (multi-choice question) by nationality

Future plans	Overall	China	India	USA	Malaysia	Nigeria	Canada	Pakistan	Hong Kong	Taiwan	Singapore
	2010	2010	2010	2010	2010	2010	2010	2010	2010	2010	2010
Seek short term employment in UK	37% (2,262)	33% (393)	46% (320)	36% (175)	37% (117)	45% (127)	33% (62)*	46% (74)*	29% (99)*	45% (67)*	27% (26)**
Seek long term employment in UK	45% (2,305)	32% (397)	55% (326)	42% (180)	51% (118)	54% (129)	33% (62)*	63% (78)*	41% (99)*	56% (68)*	45% (27)**
Undertake further study in UK	49% (2,296)	43% (387)	39% (328)	29% (179)	55% (120)	69% (128)	32% (62)*	56% (77)*	42% (99)*	52% (67)*	44% (27)**
Visit UK for holiday/leisure	84% (2,298)	86% (400)	75% (324)	85% (179)	88% (117)	89% (126)	87% (64)*	83% (77)*	81% (98)*	94% (68)*	81% (27)**
Apply for perm. residence in UK	29% (2,287)	25% (395)	27% (327)	24% (175)	30% (117)	39% (129)	14% (63)*	47% (79)*	31% (95)*	33% (68)*	41% (27)**
Develop professional links with orgs. in UK	77% (2,315)	67% (398)	83% (329)	73% (178)	77% (118)	94% (129)	63% (63)*	91% (79)*	61% (98)*	78% (68)*	64% (28)**
Collaborate with UK unis/colleges for academic /research purposes	61% (2,300)	51% (398)	58% (324)	50% (178)	60% (118)	83% (129)	42% (63)*	78% (78)*	47% (98)*	54% (68)*	67% (27)**
Seek to remain connected with my university	87% (2,319)	90% (399)	87% (329)	73% (178)	89% (121)	94% (128)	72% (63)*	95% (78)*	77% (98)*	91% (68)*	85% (28)**

*Number of responses is below 100

**Number of responses is below 50

Table 4.6.3b - Likelihood of 2008 graduates to undertake various activities in the next 5 years (multi-choice question) by nationality

Future plans	Overall	China	India	USA	Malaysia	Nigeria	Canada	Pakistan	Hong Kong	Taiwan	Singapore
	2008	2008	2008	2008	2008	2008	2008	2008	2008	2008	2008
Seek short term employment in UK	28% (1,624)	19% (164)	27% (183)	23% (127)	32% (120)	36% (93)*	12% (64)*	33% (87)*	26% (66)*	37% (48)**	37% (27)**
Seek long term employment in UK	38% (1,643)	29% (168)	53% (189)	33% (128)	45% (119)	42% (94)*	26% (65)*	54% (89)*	35% (65)*	44% (50)*	37% (27)**
Undertake further study in UK	44% (1,641)	39% (167)	36% (188)	20% (125)	48% (119)	61% (96)*	15% (64)*	54% (92)*	35% (66)*	38% (50)*	34% (27)**
Visit UK for holiday/leisure	85% (1,632)	91% (166)	77% (179)	85% (129)	84% (121)	86% (95)*	78% (66)*	80% (91)*	86% (66)*	86% (50)*	89% (27)**
Apply for perm. residence in UK	27% (1,635)	30% (167)	29% (187)	16% (129)	23% (119)	46% (95)*	13% (64)*	49% (90)*	21% (64)*	37% (49)**	19% (27)**
Develop professional links with orgs. in UK	75% (1641)	75% (166)	77% (190)	64% (128)	70% (120)	96% (96)*	65% (64)*	83% (90)*	65% (65)*	66% (50)*	67% (27)**
Collaborate with UK unis/colleges for academic /research purposes	59% (1,642)	53% (166)	60% (189)	39% (128)	53% (120)	84% (95)*	33% (64)*	65% (91)*	38% (66)*	52% (50)*	40% (27)**
Seek to remain connected with my university	86% (1,650)	90% (167)	90% (189)	65% (127)	91% (119)	96% (96)*	62% (65)*	93% (91)*	88% (65)*	82% (50)*	82% (27)**

4.7 Recommendation

Recommending the specific institution

The likelihood of recommending UK HEIs to others was strong amongst graduates from all the levels of study considered and for both cohorts, with over 80% stating that they would encourage others to apply to their institution for study (figure 4.7.1). There is no marked difference in the results when comparing between different levels of study.

Figure 4.7.1 - Recommendation rating for the institution from 2008 and 2010 graduates by study level

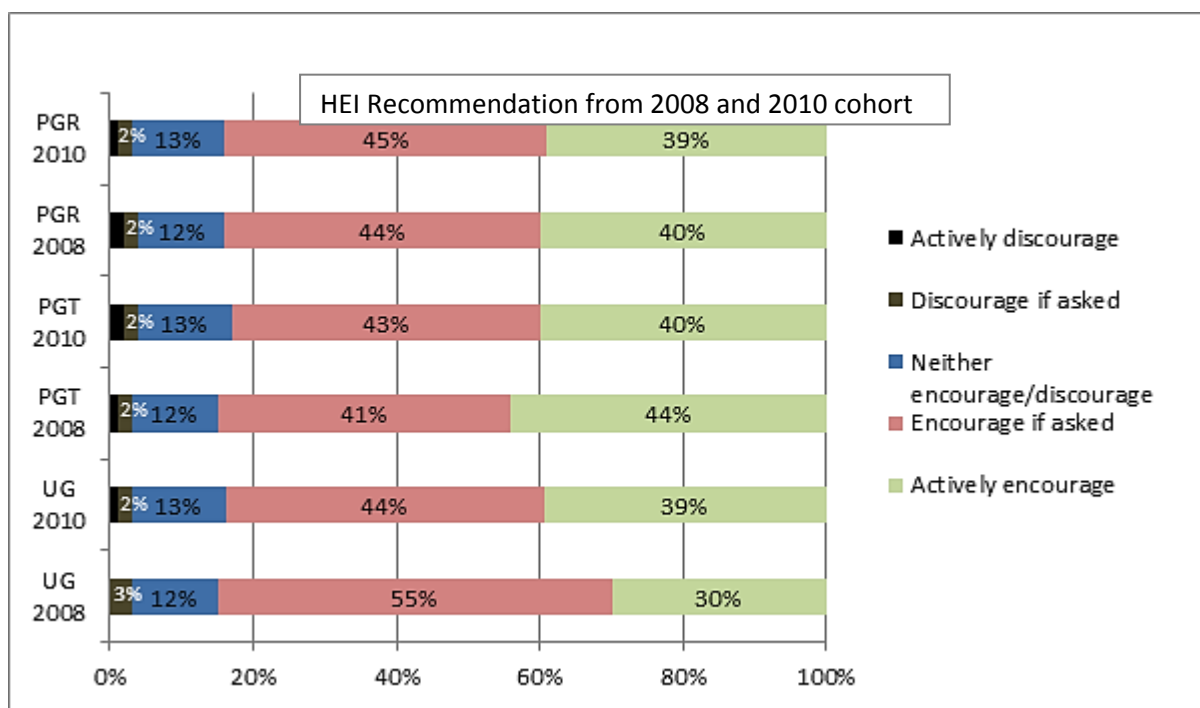

Table 4.7.1 compares 2010 graduates' recommendation of their UK institution with international students in 2010 and UK-domiciled students in 2010 using ISB and SB results. It can be seen that international graduates who left in 2010 are more positive about encouraging people to apply to their institution.

Table 4.7.1 - Comparison of recommendation rating with UK international students and UK-domiciled students using the ISB and the SB

Would you recommend your institution to people considering studying for a degree?	2010 i-GO	2010 ISB	2010 SB
I would actively encourage people to apply	40%	34%	41%
If asked, I would encourage people to apply	44%	44%	39%
I would neither encourage nor discourage people	13%	16%	15%
If asked, I would discourage people from applying	2%	4%	4%
I would actively discourage people from applying	1%	2%	2%

There are some notable differences when looking at recommendation between respondents from different countries. In both the 2008 and 2010 cohorts, Chinese students were the most likely to recommend their HE institution to others, with 91% likely to either recommend their institution when asked, or actively recommend it. For both cohorts, Nigerian students were the second most likely to recommend their institution to others, with 88% stating that they would encourage others in 2010 and 86% in 2008. Graduates from the US appear to be amongst the least likely to recommend their HE institution to others. In 2008 they were the least likely, with 72% stating that they would encourage others. In 2010 they were on a similar footing to students from India and Hong Kong. For all three countries 76% stated that they would encourage others to attend their HE institution.

Recommending the UK

Figure 4.7.2 - Recommendation rating for the UK from 2008 and 2010 graduates by study level

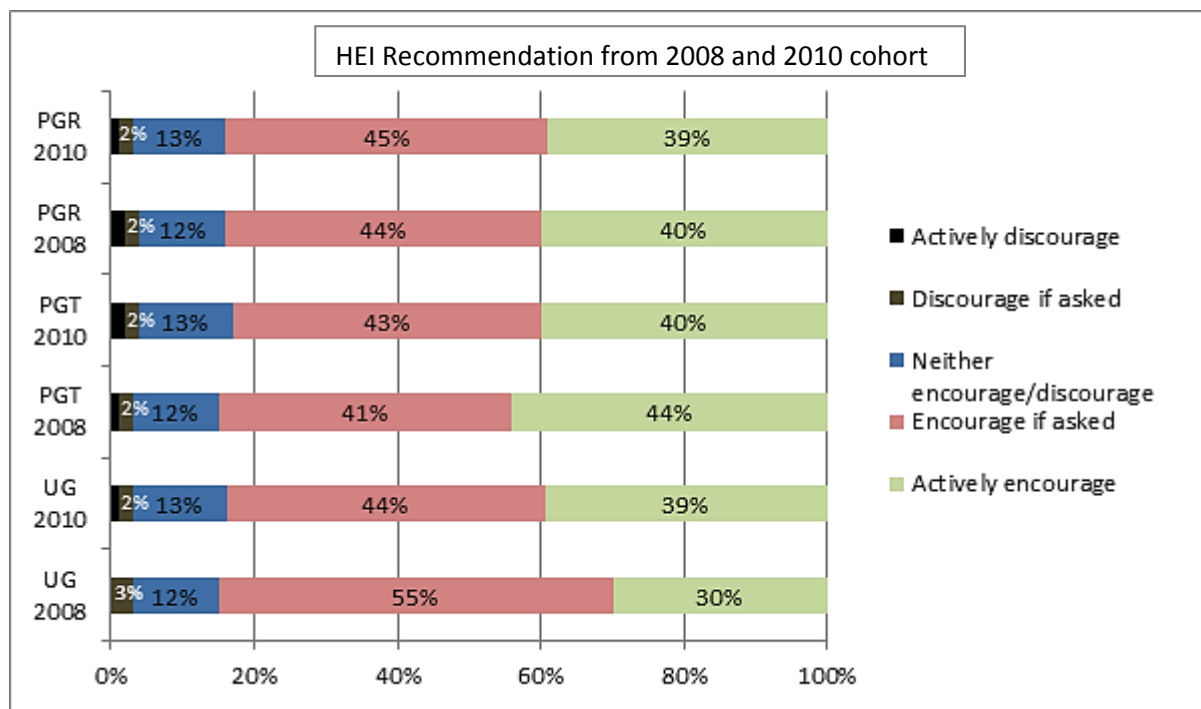

As with graduates recommending their institutions, the likelihood of recommending the UK more generally is very high amongst graduates from all the levels of study and for both cohorts (figure 4.7.2). Positive recommendation is over 80% in most cases but compared to the results for HEIs, fewer would 'actively encourage', with more respondents encouraging if asked.

When comparing graduates from different countries, those from China again were the most likely to recommend the UK to people considering studying for a degree. The likelihood to recommend was very strong, with 90% of Chinese respondents from the 2010 cohort stating that they would encourage others and 86% from the 2008 cohort. This is similar but slightly less pronounced than the finding for recommending HE institutions. In contrast to the findings for HE institutions, graduates from the US were not the least likely to recommend the UK to others. In fact for the 2010 cohort they were the third most likely to encourage others after China and Malaysian graduates. 82% of US graduates stated that they would encourage others to apply to the UK. The graduates that were the least likely to encourage other people to consider studying in the UK were from India where 60% stated that they would encourage others. This was down from 65% in the 2008 cohort, which also positioned them as the least likely advocates.

5. Conclusions

The findings of this study are extremely positive for the UK. International graduates, whether they remain in the UK, return home, or go elsewhere overseas, have good employment prospects in graduate-level jobs.

Out of the graduates surveyed in both waves, a high percentage are in employment, further study, and/or training. The benefits of a UK higher degree are not only apparent in new graduates but are also seen in those who graduated a few years ago. 94% and 95% of graduates from 2008 and 2007 respectively, are in employment or further study/training. Furthermore, recent graduates are less intent on remaining in the UK for a long period of time – a greater percentage are returning home or going to another country for work or study.

The graduates surveyed evidently enjoyed their time as a student in the UK, with a high percentage willing to recommend their institution and the UK to others for study. The overwhelming majority were satisfied with the whole experience (learning, living, and support services provided), and felt welcome in the UK when they first arrived.

A high percentage of graduates would also like to remain connected with the university over the next five years and HEIs should act upon this willingness of international graduates to remain involved. The UK can remain optimistic that its international graduates are recognising and enjoying the benefits of its higher education system and progressing onto successful career paths.

6. Recommendations

In 2010, there were a number of recommendations to HESA regarding the feasibility of including non-EU international graduates in the DLHE survey. After completing the full process of i-GO, i-graduate finds that these recommendations are still relevant after 2011 and are therefore have been re-iterated here.

In order to reflect non-EU graduate outcomes meaningfully and accurately, we recommend that a later capture point should be used in addition to the '6 months out' capture point from completion of study (as currently used in the DLHE for UK/EU graduates). From the results of the study, the 30-month data capture point provides data that better reflects non-EU graduates' employment and career outcomes. It is apparent and inevitable from the ISTS data that graduate employment levels are more developed at 30 months compared with 6 months.

The study demonstrates that there are very favourable outcomes for international students who come to the UK to study – a high percentage of international alumni are either in employment or further study (86% of 2010 graduates, and 95% of 2008 graduates), and reflect well upon their time at university in the UK. i-graduate recommends that the UK publicise these outcomes more widely in the hope of attracting more students to study here for their tertiary degrees.

Higher education institutions need to stay connected with their alumni and sustain an active alumni network as international alumni will promote the UK's reputation abroad. HEIs could look to see what opportunities there are for fostering this connection and to publicise them widely internationally.

i-graduate previously suggested that it is too soon to consider making the collection of graduate destinations data from non-EU graduates compulsory as institutions need time to build up the necessary contact details. We also stress that there is not yet sufficient evidence on which to base a decision on target minimum response rates for these graduates without institutions carrying out the full DLHE survey. In the consultation and registration process last year and this year, it was apparent that numerous institutions do not have the mechanisms in place to coordinate a survey for their non-EU graduates of a specific cohort. HESA could provide guidance to institutions to facilitate this process.

However, as international students constitute 11% of the UK HE population¹⁸, they constitute a significant proportion of the talent base and income of UKHE. Therefore we feel it is important that graduate outcomes for international non-EU graduates are tracked and we are pleased to note that HESA are including them in the future 2011/12 DLHE wave and foreseeable waves thereafter.

¹⁸ http://www.hesa.ac.uk/index.php?option=com_content&task=view&id=1897&Itemid=239

Appendix 1 – Steering Group Members

Organisation	2010	2011
BIS	Geoffrey Shoesmith Mary Gurteen Monika Sandhu	Charles Ritchie Brian Johnson Cate Dobson
i-graduate	William Archer Jess Davison John Taylor	William Archer Tom Baynton Kirsty Bryant Jacqueline Cheng
HESA	Catherine Benfield	Sarah Grimes
Research Councils UK	Kate Reading	Kate Reading
UK Border Agency	Samantha Dowling	Sarah Poppleton

Appendix 2 – List of participating institutions in 2011

1	Arts University College Bournemouth	33	University of Bradford
2	Aston University	34	University of Central Lancashire
3	Birmingham City University	35	University of Chester
4	Cardiff University	36	University of Dundee
5	De Montfort University	37	University of East Anglia
6	Durham University	38	University of Essex
7	Glasgow Caledonian University	39	University of Glasgow
8	Glyndwr University	40	University of Gloucestershire
9	Heriot-Watt University	41	University of Greenwich
10	Kingston University	42	University of Huddersfield
11	Lancaster University	43	University of Kent
12	Leeds Metropolitan University	44	University of Leeds
13	Liverpool Hope University	45	University of Leicester
14	Liverpool John Moores University	46	University of Lincoln
15	Loughborough University	47	University of Liverpool
16	Manchester Metropolitan University	48	University of Manchester
17	Middlesex University	49	University of Northampton
18	Newcastle University	50	University of Nottingham
19	Northumbria University	51	University of Portsmouth
20	Norwich University College of the Arts	52	University of Sheffield
21	Queen Margaret University	53	University of Southampton
22	Queen's University Belfast	54	University of Stirling

23	Robert Gordon University	55	University of Sussex
24	Roehampton University	56	University of Ulster
25	Staffordshire University	57	University of Wales Institute, Cardiff
26	Swansea University	58	University of Wales, Newport
27	Teesside University	59	University of Westminster
28	Thames Valley University	60	University of Winchester
29	The Royal Veterinary College	61	University of Wolverhampton
30	University College London	62	University of Worcester
31	University of Birmingham	63	University of York
32	University of Bolton		

Additional institutions offering DLHE information

- 1 University of Cambridge
- 2 University of Oxford
- 3 University of Warwick

Appendix 3 – Comparison of i-GO sample and HESA population

Non-EU student qualifiers by domicile on entering course in 2009/10 and 2007/08

Source: Higher Education Statistics Agency¹⁹

2010 cohort – 6months after graduating (surveyed in 2nd wave)

		i-GO		HESA 2009/2010	
		N	%	N	%
Nationality*	China	1,060	19%	50,765	18%
	India	643	12%	36,245	13%
	USA	653	12%	12,620	4%
	Malaysia	237	4%	13,365	5%
	Nigeria	215	4%	15,465	6%
	Canada	197	4%	5,110	2%
	Pakistan	147	3%	9,175	3%
	Hong Kong	163	3%	9,295	3%
	Taiwan	130	2%	4,630	2%
	Singapore	133	2%	3,530	1%
Gender**	Male	2,798	51%	155,195	55%
	Female	2,697	49%	125,575	45%
Level of study*	UG	1,408	26%	103,535	37%
	PGT	2,663	48%	121,300	43%
	PGR	1,414	26%	28,405	10%
Overall		5,507		280,780	

¹⁹ http://www.hesa.ac.uk/index.php?option=com_content&task=view&id=1897&Itemid=239

2008 cohort – 2 ½ years after graduating (surveyed in 2nd wave)

		i-GO		HESA 2007/2008	
		N	%	N	%
Nationality*	China	223	11%	41,375	18%
	India	248	12%	23,880	10%
	USA	152	7%	10,975	5%
	Malaysia	149	7%	11,125	5%
	Nigeria	121	6%	10,695	5%
	Canada	72	3%	4,415	2%
	Pakistan	116	5%	8,475	4%
	Hong Kong	92	4%	8,730	4%
	Taiwan	62	3%	5,170	2%
	Singapore	28	1%	2,685	1%
Gender**	Male	1136	54%	125,675	55%
	Female	933	44%	103,950	45%
Level of study*	UG	555	26%	86,750	42%
	PGT	1,385	66%	90,705	44%
	PGR	167	8%	27,225	13%
Overall		2,113		229,645	

*do not add up to 100% as there are other nationalities and courses not specified as UG, PGT, or PGR that have not been included in this table.

**do not add up to the total overall figure as not everyone answered this question.

Appendix 4 –DLHE survey (courtesy of HESA)

Please click on the below web-link to download a copy of the 'Destinations of Leavers from Higher Education 2009/10' questionnaire:

http://www.hesa.ac.uk/dox/datacoll/C09018/ENGLISH_HESA_Quest_4pp_Jan_11.pdf

Appendix 5 – i-GO questionnaire

International Graduate Outcomes Questionnaire

Final version as distributed

The institution name will be inserted automatically at the points inserted ^insertuni(0)^

Welcome to ^insertuni(0)^ International Graduate Outcomes Study

We would like to invite you to take part in a study to tell us what you are doing now, following the completion of your studies here - are you working, undertaking further study or research, or taking some time out?

We are interested in knowing what you were doing on **19 April 2010**. You can fill in the questionnaire online at any time from now until 17 May 2010, but 19 April 2010 is the date we are interested in so that we can compare everyone's information.

The questionnaire should take no longer than 10 minutes to complete and most of the questions just require you to select a box with your answer.

Please click on the Start Survey button or the arrow at the bottom of the page to enter the survey.

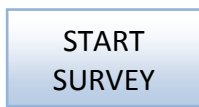

What will the research be used for?

The results will help prospective and current international students at ^insertuni(0)^ to see what paths in life are followed by graduates from non-EU countries and the results will inform ^insertuni(0)^ policy & careers advice. The results will also be merged with those from other universities/colleges to provide overall information that will influence central policy and decision making about education.

Who is conducting this research?

This survey is administered by i-graduate, an independent research organisation. All the survey procedures are carried out in line with the requirements of the UK Data Protection Act 1998 and the Market Research Society Code. If you want to know more about i-graduate, please [click here](#) to view the privacy policy and FAQs.

How will my data be used?

All individual questionnaires are anonymised and the results are analysed in aggregate form. All the anonymised records will be returned to us at ^insertuni(0)^. You can choose to share your personal information with us at ^insertuni(0)^ if you wish, so that we can update your records and keep in better touch with you in the future. This is your choice and you can remain anonymous if you choose. Your response will be anonymised and combined with responses from other graduates from other UK institutions and reported to the Department for Business, Innovation and Skills (BIS), who have commissioned the project. Neither you nor your institution will be identified in any data or reporting provided to BIS.

If you need any assistance in completing the questionnaire, please contact info@i-graduate.org.

DEMOGRAPHICS

So that we can analyse your response, please tell us...

Q1. Where are you from?

Drop-down list of countries
Compulsory question

Q2. Gender

Are you...?

- Male
 Female

Q3. Please select your year of birth

Drop down list of years 1920-1995

Q4. When did you complete your studies at ^insertuni(0)^?

Compulsory question

(Please select the month you finished studying, not the month you graduated). If you are not sure, please estimate the month when you completed your studies.

Drop down list of month and year

Q5. What level of study was your course at ^insertuni(0)^?

- Higher degree, mainly by research (PhD, DPhil, MPhil, etc.)
 Higher degree, mainly by taught course (MA, MSc, etc.)
 Postgraduate diploma or certificate (including PGCE)
 First degree (BA, BSc, etc.)
 Other diploma or certificate
 Professional qualification, e.g. Accountancy
 Other qualification

Q6. Your main area of study at ^insertuni(0)^:

Drop down list of standard JACS classification of area of study

Q7. Please state:

Q7a) Your course title

If Q5 does not = PGR

Q7b) Your focus of research

If Q5 = PGR

Q7c). What was your study type?

- Student Exchange
 Study abroad

- Full-time
- Part-time
- Distance Learning
- Other

Q8. What degree class did you achieve at ^insertuni(0)^?

If Q5 = First degree (BA, BSc, etc.)

- First class
- Upper second (2:1)
- Lower second (2:2)
- Third class/pass
- Unclassified

Q9. How did you fund your studies whilst at ^insertuni(0)^?

(please tick all that apply)

- Own funds
- Loan
- Family
- Employer
- Host country government scholarship
- Home country government scholarship
- University scholarship/bursary
- Other scholarship
- Research Council funding
- Welsh Assembly Learning Grant
- SAAS
- Charity or trust
- Other sponsor
- Other

SECTION A: What were you doing on 19 April 2010?

We are interested in knowing what you were doing on 19 April 2010. This is the date we are interested in so that we can compare everyone's information.

Q10. Which of the following statements best describes your employment circumstances on 19 April 2010?

Compulsory question

I was...

- Employed full-time in paid work
- Employed part-time in paid work
- Self-employed/freelance
- Doing voluntary work/other unpaid work
- Permanently unable to work/retired
- Temporarily sick or unable to work/looking after the home or family
- Taking time out in order to travel
- Due to start a job within the next month
- Unemployed and looking for employment, further study or training
- Not employed but NOT looking for employment, further study or training
- Doing something else

Q11. On 19 April 2010 were you:

- Involved in full-time study, training or academic research
- Involved in part-time study, training or academic research
- Distance learning
- Not involved in study, training or academic research

SECTION B: Your employment on 19 April 2010

Section B shown if Q10 = Employed full-time, part-time, self-employed, voluntary work

We are interested in any work and/or further study you were doing on **19 April 2010**. If you had more than one job on 19 April 2010, please tell us about your main job.

Q12. In which country was your place of work on 19 April 2010?

Compulsory question

Drop-down list of countries

Q13. In which state/city/region was your place of work?

Drop-down list of states/city/regions depending on answer to Q12

Q14. What is its postcode? If Q12 = UK

Don't know your employers' postcode? Go to the Royal Mail postcode website

Q15. Or, if you don't know the postcode of your place of work then please tell us the town in which your place of work is located:

Q16. Thinking about your employer on 19 April 2010, which of the following best describes what the organisation mainly does? Drop down list of main SIC descriptors from HESA	Q 16a. Please tell us some more detail about what the organisation mainly does: Drop down list of secondary SIC descriptors Secondary list only displayed dependent on answer to Q16.
Main descriptor e.g. Computing/IT	e.g. computer programming, consultancy, web design and related activities

Q17. Please tell us your job title:

Q18. Briefly describe your duties (e.g. maintaining and updating company intranet)

Q19. What is the name of the organisation you were working for on 19 April 2010?

Q20. Approximately how many people work in the entire organisation (i.e. all branches, departments, etc.)?

- 1 - 9
- 10 - 49
- 50 - 249
- 250 - 499
- 500 - 999
- 1,000 - 4,999
- 5,000 - 9,999
- Over 10,000
- Don't know

Q21. Which of the following best describes the basis on which you were employed on 19 April 2010?

- On a permanent or open-ended contract
- On a fixed-term contract lasting 12 months or longer
- On a fixed-term contract lasting less than 12 months
- Self-employed/freelance
- Temporarily, through an agency
- Temporarily, other than through an agency
- Other

Q22. What was your annual pay to the nearest thousand GBP (£), before tax?

If you were employed for less than a year or were employed part-time, please estimate your pay to the full-time annual equivalent.

If you are unsure of how your own currency converts to GBP (£) please visit www.xe.com

This question is optional. If you would rather not answer, please select 'I'd rather not say' from the list below.

- | | |
|--|---|
| <input type="radio"/> I'd rather not say | <input type="radio"/> £90,000 - £94,999 |
| <input type="radio"/> Less than £4,999 | <input type="radio"/> £95,000 - £99,999 |
| <input type="radio"/> £5,000 - £9,999 | <input type="radio"/> £100,000 - £104,999 |
| <input type="radio"/> £10,000 - £14,999 | <input type="radio"/> £105,000 - £109,999 |
| <input type="radio"/> £15,000 - £19,999 | <input type="radio"/> £110,000 - £114,999 |
| <input type="radio"/> £20,000 - £24,999 | <input type="radio"/> £115,000 - £119,999 |
| <input type="radio"/> £25,000 - £29,999 | <input type="radio"/> £120,000 - £124,999 |
| <input type="radio"/> £30,000 - £34,999 | <input type="radio"/> £125,000 - £129,999 |
| <input type="radio"/> £35,000 - £39,999 | <input type="radio"/> £130,000 - £134,999 |
| <input type="radio"/> £40,000 - £44,999 | <input type="radio"/> £135,000 - £139,999 |
| <input type="radio"/> £45,000 - £49,999 | <input type="radio"/> £140,000 - £144,999 |
| <input type="radio"/> £50,000 - £54,999 | <input type="radio"/> £145,000 - £149,999 |
| <input type="radio"/> £55,000 - £59,999 | <input type="radio"/> £150,000 - £154,999 |
| <input type="radio"/> £60,000 - £64,999 | <input type="radio"/> £155,000 - £159,999 |
| <input type="radio"/> £65,000 - £69,999 | <input type="radio"/> £160,000 - £164,999 |
| <input type="radio"/> £70,000 - £74,999 | <input type="radio"/> £165,000 - £169,999 |
| <input type="radio"/> £75,000 - £79,999 | <input type="radio"/> £170,000 - £174,999 |
| <input type="radio"/> £80,000 - £84,999 | <input type="radio"/> £175,000 - £179,999 |
| <input type="radio"/> £85,000 - £89,999 | <input type="radio"/> £180,000 - £184,999 |

- £185,000 - £189, 999
- £190,000 - £194, 999

- £195,000 - £199, 999
- Over £200,000

Q23. Would you say that for the country you are working in, your income is:

- Well above average
- Above average
- Average
- Below average
- Well below average

Q24. Which of the following best describes your role on 19 April 2010?

- All my work is given to me by others
- My work is mainly given to me by others
- I manage myself and my own work
- I manage myself and others

Q25. Approximately how many other employees do you manage?

If Q24 = I manage myself and others

- 1-5
- 6-9
- 10-19
- 20-29
- 30-39
- 40-49
- More than 50

Q26. Would you have been able to get the job you were doing on 19 April 2010 without the qualification you recently obtained (the actual qualification, not the subject of study)?

- No: the qualification was a requirement
- Possibly: but the qualification did give me an advantage
- Yes
- Don't know

Q27. As far as you are aware, what was most important to your employer?

- A qualification from a university/college in the UK
- A qualification from ^insertuni(0)^
- The subject(s) studied
- The level of study
- Don't know

Q28. Why did you decide to take the job you were doing on 19 April 2010?

(Please tick all that apply)

- It fitted into my career plan/it was exactly the type of work I wanted
- It was the best job offer I received/only job offer I received
- It was an opportunity to progress in the organisation
- To see if I would like the type of work it involved
- To gain and broaden my experience in order to get the type of job I really want

- In order to earn a living/pay off debts
- It was in the right location
- The job was well-paid
- Other (please specify) _____

Q29. How did you find out about this job?*(Please tick all that apply)*

- ^insertuni(1)^'s Careers Service
- Newspaper/magazine advertisement (which one?) _____
- Employer's website (which one?) _____
- Recruitment agency (which one?) _____
- Recruitment website (which one?) _____
- Personal contacts, including family and friends, networking
- Speculative application
- Already worked there
- Don't remember
- Other _____

Q30. Thinking still about your employer on 19 April 2010: did you work for this employer before or during the programme of study you recently completed?

- Yes: before my programme of study
- Yes: during my programme of study
- Yes: both before and during my programme of study
- No

Q31. In which of the ways listed below did you work for this employer?**If Q30 = Yes***(Please tick all that apply)*

- On a training/sandwich placement
- On another kind of placement or project work
- As a holiday job
- Full-time or part-time work all year round
- Full-time or part-time work during term time
- In other ways

Q32. Since you completed your qualification, how many different employers have you worked for?**Q32 shown if 2007 cohort**

In the UK	{display selection ranging from 1 to 10 for respondent to click}
Outside the UK	{display selection ranging from 1 to 10 for respondent to click}

Q33. Since you completed your qualification, approximately how many positions have you held?*(please include positions within the same organisation e.g. promotion)*

In the UK	{display selection ranging from 1 to 20+ for respondent to
-----------	--

Hide if Q32 = outside UK only	click}
Outside the UK Hide if Q32 = UK only	{display selection ranging from 1 to 20+ for respondent to click}

Q34. Since you completed your qualification at ^insertuni(0)^, have you undertaken any further study or academic research?

If Q11 = 'Not involved in study, training or academic research'

- Yes, in the UK
- Yes, in another country
- No

Q35. Which of the following best describes the qualification(s) you have obtained since you completed your qualification at ^insertuni(0)^?

If Q34 = Yes

(Please tick all that apply)

- Higher degree, mainly by research (PhD, DPhil, MPhil etc.)
- Higher degree, mainly by taught course (MA, MSc etc.)
- Postgraduate diploma or certificate (including PGCE)
- First degree (BA, BSc etc.)
- Other diploma or certificate
- Professional qualification, e.g. Accountancy
- Other qualification

SECTION C – Your further study, training or research on 19 April 2010

If Q11 = Yes to study, training or research

Q36. In which country were you studying/training/researching on 19 April 2010?

Drop-down list of countries

Q37. Is the qualification you were working towards awarded by a UK university/college?

If Q36 = not UK

- Yes
- No
- I don't know

Q38. Please tell us the name of your teaching university/college (the place where you attend classes)
Q39. If it is different from the teaching university/college, please tell us the name of the awarding university/college (the university/college name on the qualification)*If the teaching and awarding institution are the same, please leave this question blank.*

Name: _____

Country: _____

Q40. Which of the following best describes the qualification you were aiming for on 19 April 2010?

- Higher degree, mainly by research (PhD, DPhil, MPhil etc.)
- Higher degree, mainly by taught course (MA, MSc etc.)
- Postgraduate diploma or certificate (including PGCE)
- First degree (BA, BSc etc.)
- Other diploma or certificate
- Professional qualification, e.g. Accountancy
- Other qualification
- Not aiming for a qualification

Q41a) What is the name of the course you were registered on? (e.g. MSc in Interactive Media)

If Q40 does not = PGR

Q41b) What is the focus of your research?

If Q40 = PGR

Q41c) What was the main area of your study, training or research on 19 April 2010?

Drop down list of standard JACS classification of area of study

Q42. Why did you decide to undertake further study, training or research?

(Please tick all that apply)

- Because it was a requirement of my employment on 19 April 2010 that I did
- To develop a broader or more specialist range of skills or knowledge
- To change or improve my career options
- Because I was interested in the content of the course
- Because I had enjoyed my first course and wanted to continue studying
- I wanted to go on being a student/I wanted to postpone job hunting
- I had been unable to find a suitable job
- Other

Q43. How were you mainly funding your study, training or research on 19 April 2010?

- Own funds
- Loan
- Family
- Employer
- Host country government scholarship
- Home country government scholarship
- University scholarship/bursary
- Other scholarship
- Research Council funding
- Welsh Assembly Learning Grant
- SAAS
- Charity or trust
- Other sponsor
- Other

SECTION D: Employment in the UK

Section D displayed to all respondents

Q44. Thinking back to when you started the course you completed ^month()^, which of the following best describes what motivated you to take the course?

- I thought it would help me to progress in my career or job
- I thought it would help me to change careers or jobs
- I was interested in the subject matter of the course
- Other reason

Q45. When you applied to study in the UK, were you aware of any scheme that allowed you to work in the UK for a period after completing your course?

- Yes
- No

Q46. Can you remember which scheme it was?

If Q46 = yes

- Science and Engineering Graduate Scheme (SEGS)
- Science and Engineering Graduate Scheme (SEGS) Plus
- Fresh Talent Scotland (shown only to those who attended HEIs in Scotland)
- International Graduate Scheme (2009 cohort)
- Post Study Work scheme (2009 cohort)
- Don't know

Q47. Did the availability of this type of scheme influence your decision to apply to a UK university?

If Q46 = yes

- Yes
- Maybe
- No
- Don't know

Q48. Were you employed in the UK during your course or immediately before it?

- No
- Yes – I was working in a programme or placement through my course of study
- Yes – I was working outside my course in an area relevant to my future career plans
- Yes – I was working outside my course in an area not relevant to my future career plans

Qs 50-53 only shown if Q12 = not UK

Q49. For how many months did you remain in the UK after you completed your studies at ^insertuni(0)^?

Drop down list of months displayed based on number of months since completion of studied in Q4

Q50. Were you employed in the UK during this time after you completed your studies?

- Yes, full time

- Yes, part-time
- No

Q51. For approximately how many months were you employed in the UK?
Drop down list of months displayed, if Q51 = yes

Q52. How many of the job(s) you did in the UK would you have been able to get without the qualification you recently obtained?

If Q51 = yes

- The qualification was required for all the jobs I did in the UK
- I would have been able to get one or more jobs without the qualification
- I would have been able to get all of the jobs without the qualification
- Don't know

Q53. For how long do you plan to remain in the UK?

If Q12 = UK

- Less than 1 month
- 1 to 2 months
- 3 to 4 months
- 5 to 6 months
- 7 to 12 months
- Up to 2 years
- Up to 3 years
- Up to 4 years
- More than 4 years
- Permanently
- Don't know

We are interested to find out more about the types of visas held by non-EU students in the UK. These questions are optional. If you would prefer not to answer then please leave the question blank.

Q54. Immediately after you completed your studies, what type of visa did you apply for to extend your stay in the UK?

If Q50 = not 0

- Work Visa (Main applicant)
- Work Visa (Dependant)
- Student Visa (Main applicant)
- Student Visa (Dependant)
- Marriage Visa
- Citizenship/Leave to Remain
- Visitor visa (up to 6 months) with work rights
- Other
- I did not work in the UK after I completed my studies
- I don't know

Q55a) Can you tell us which Work Visa you applied for:

If Q55 = Work Visa (Main applicant or Dependant)

Points-Based System Work Visa - Tier 1 - Highly Skilled

- General
- Entrepreneur
- Investor
- Post-study

Points-Based System Work Visa - Tier 2 - Skilled Migrant:

- General
- Minister of religion
- Sportsperson
- Intra-company transfer (ICT)
- Points-Based System Work Visa - Tier 5 - Temporary workers
- Pre-Points-Based System Work Visa
- Other non-Points-Based System Work Visa
- I don't know

Q55b) Can you tell us which Student Visa you applied for:

If Q55 = Student Visa (Main applicant or Dependant)

- Points-Based System Student Visa (Tier 4)
- Pre-Points-Based System Student Visa
- I don't know

Q56a) What type of visa did you hold on 19 April 2010?

If Q12 = UK

- Work Visa (Main applicant)
- Work Visa (Dependant)
- Student Visa (Main applicant)
- Student Visa (Dependant)
- Marriage Visa
- Citizenship/Leave to Remain
- Visitor visa (up to 6 months) with work rights
- Other
- I did not work in the UK after I completed my studies
- I don't know

Q56b) Can you tell us which Work Visa you held:

If Q56 = Work Visa (Main applicant or Dependant)

Points-Based System Work Visa - Tier 1 - Highly Skilled:

- General
- Entrepreneur
- Investor
- Post-study

Points-Based System Work Visa - Tier 2 - Skilled Migrant:

- General
- Minister of religion
- Sportsperson
- Intra-company transfer (ICT)
- Points-Based System Work Visa - Tier 5 - Temporary workers
- Pre-Points-Based System Work Visa
- Other non-Points-Based System Work Visa
- I don't know

Q56c) Can you tell us which Student Visa you held:

If Q56 = Student Visa (Main applicant or Dependant)

- Points-Based System Student Visa (Tier 4)
- Pre-Points-Based System Student Visa
- I don't know

Q57. Did you apply for or extend your UK student visa after 31st March 2009?

2009 cohort only

- Yes
- No
- I'm not sure

Q58. Excluding the outcome of your application, how satisfied or dissatisfied were you with the visa application process overall?

- Very satisfied
- Satisfied
- Dissatisfied
- Very dissatisfied

SECTION E: Reflections and Future Plans

Q59. Reflecting on your time at ^insertuni(0)^, to what extent do you agree with the following statements:

	Strongly disagree	Disagree	Agree	Strongly Agree
My UK degree was worth the financial investment	<input type="checkbox"/>	<input type="checkbox"/>	<input type="checkbox"/>	<input type="checkbox"/>
Having a qualification from the UK means I can progress more quickly in my chosen career	<input type="checkbox"/>	<input type="checkbox"/>	<input type="checkbox"/>	<input type="checkbox"/>
Being an alumnus of ^insertuni(0)^ means I can progress more quickly in my chosen career	<input type="checkbox"/>	<input type="checkbox"/>	<input type="checkbox"/>	<input type="checkbox"/>
Having a qualification from the UK means I can command a higher salary	<input type="checkbox"/>	<input type="checkbox"/>	<input type="checkbox"/>	<input type="checkbox"/>
Being an alumnus of ^insertuni(0)^ means I can command a higher salary	<input type="checkbox"/>	<input type="checkbox"/>	<input type="checkbox"/>	<input type="checkbox"/>
I am satisfied with the learning experience at ^insertuni(0)^	<input type="checkbox"/>	<input type="checkbox"/>	<input type="checkbox"/>	<input type="checkbox"/>
I am satisfied with the living experience at ^insertuni(0)^	<input type="checkbox"/>	<input type="checkbox"/>	<input type="checkbox"/>	<input type="checkbox"/>
I am happy with the support provided by ^insertuni(0)^	<input type="checkbox"/>	<input type="checkbox"/>	<input type="checkbox"/>	<input type="checkbox"/>
I felt welcome in the UK	<input type="checkbox"/>	<input type="checkbox"/>	<input type="checkbox"/>	<input type="checkbox"/>

Q60. How likely is it that you will undertake the following in the next 5 years?

I will...

	Very unlikely	Unlikely	Likely	Very likely
Seek short term employment in the UK	<input type="checkbox"/>	<input type="checkbox"/>	<input type="checkbox"/>	<input type="checkbox"/>
Seek long term employment in the UK	<input type="checkbox"/>	<input type="checkbox"/>	<input type="checkbox"/>	<input type="checkbox"/>
Undertake further study in the UK	<input type="checkbox"/>	<input type="checkbox"/>	<input type="checkbox"/>	<input type="checkbox"/>
Visit the UK for holiday/leisure	<input type="checkbox"/>	<input type="checkbox"/>	<input type="checkbox"/>	<input type="checkbox"/>
Apply for permanent residence in the UK (settlement)	<input type="checkbox"/>	<input type="checkbox"/>	<input type="checkbox"/>	<input type="checkbox"/>

	Very unlikely	Unlikely	Likely	Very likely
Develop professional links with organisations in the UK as part of my career	<input type="checkbox"/>	<input type="checkbox"/>	<input type="checkbox"/>	<input type="checkbox"/>
Collaborate with UK universities/colleges for academic/research purposes	<input type="checkbox"/>	<input type="checkbox"/>	<input type="checkbox"/>	<input type="checkbox"/>
Seek to remain connected with ^insertuni(0)^	<input type="checkbox"/>	<input type="checkbox"/>	<input type="checkbox"/>	<input type="checkbox"/>

Q61. Would you recommend the UK to people considering studying for a degree?

- I would actively encourage people to apply
- If asked, I would encourage people to apply
- I would neither encourage nor discourage people
- If asked, I would discourage people from applying
- I would actively discourage people from applying

Q62. Would you recommend ^insertuni(0)^ to people considering studying for a degree?

- I would actively encourage people to apply
- If asked, I would encourage people to apply
- I would neither encourage nor discourage people
- If asked, I would discourage people from applying
- I would actively discourage people from applying

Thank you for taking the time to complete this questionnaire.

Q63. Are you willing for your responses to be returned to your university/college together with your name and email address?

- Yes
- No

Q64. Please enter your name, email address and date of birth:

Name	_____
Email address	_____
Date of birth	DD/MM/YYYY

Q65. We may be interested to follow up some of the responses (by email only). Is this OK?

- Yes
- No

Appendix 6 – Employment status as defined by HESA*

Employment Circumstances	Study			
	Full-time study	Part-time study	Not in study	Distance Learning
Employed full-time in paid work	W	W	W	W
Employed part-time in paid work	W	W	W	W
Self-employed/freelance	W	W	W	W
Voluntary work/other unpaid work	W	W	W	W
Permanently unable to work/retired	NA	NA	NA	NA
Temporarily sick or unable to work/looking after the home or family	W	W	NA	W
Taking time out in order to travel	NA	NA	NA	NA
Due to start a job within the next month	W	U	U	W
Unemployed and looking for employment, further study or training	W	U	U	W
Not employed but NOT looking for employment, further study or training	W	W	NA	W
Something else	W	W	NA	W
Question not answered	X	X	X	X

W - working or studying or both

U - unemployed and seeking work

NA - not available for work or study, or no information supplied

X - question not answered

*Distance learning added by i-graduate to reflect graduate responses to the i-GO questionnaire

Appendix 7 –Status of graduates, 6 months after graduation, by study level (2010 cohort)

6 months after graduation – 2nd wave

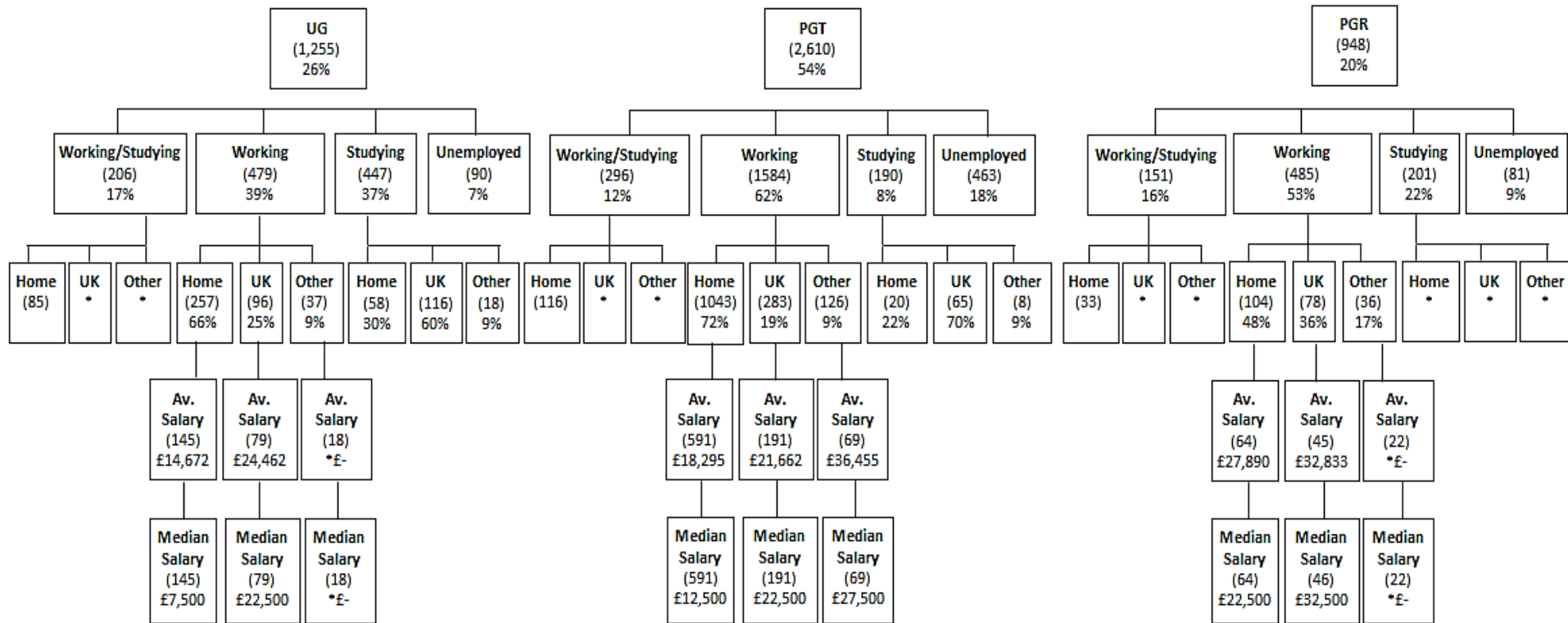

*base numbers too low to report information

Appendix 8 – Status of graduates, 2½ years after graduation, by study level (2008 cohort)

2½ years after graduation – 2nd wave

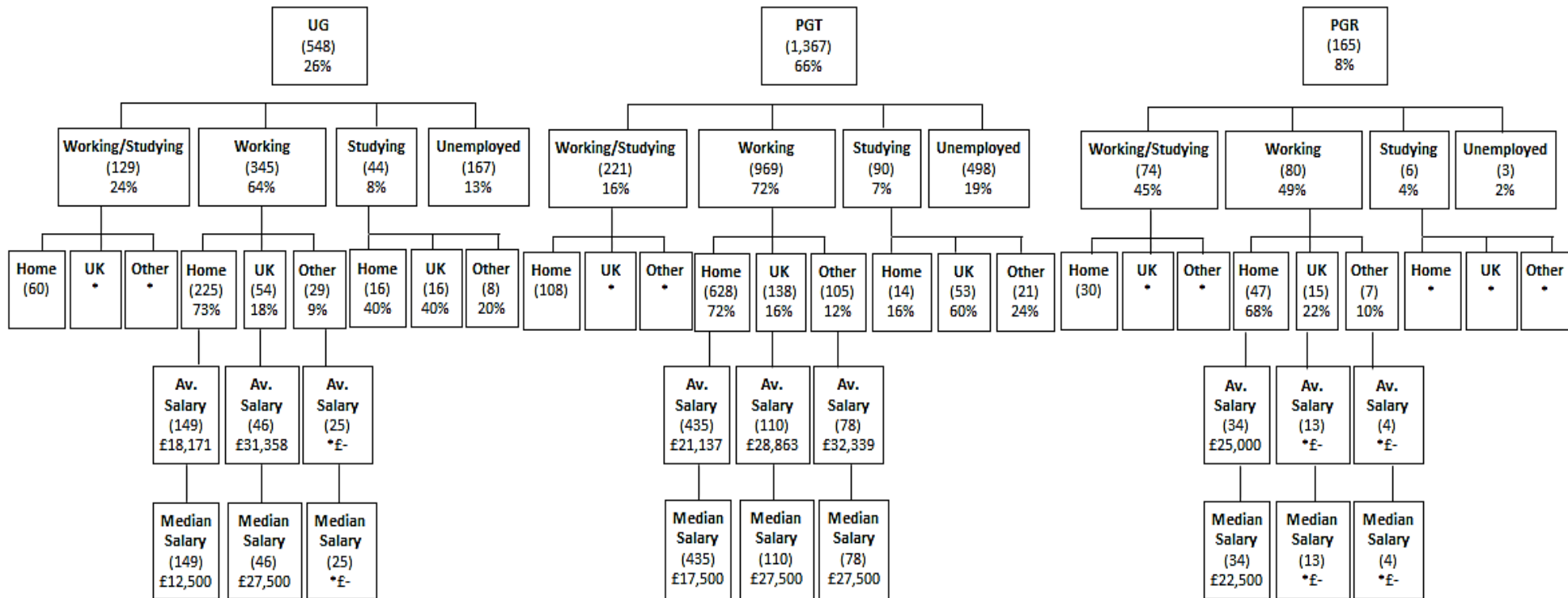

Appendix 9 – Status of graduates, 6 months after graduation, by study level (2009 cohort)

6 months after graduation – 1st wave

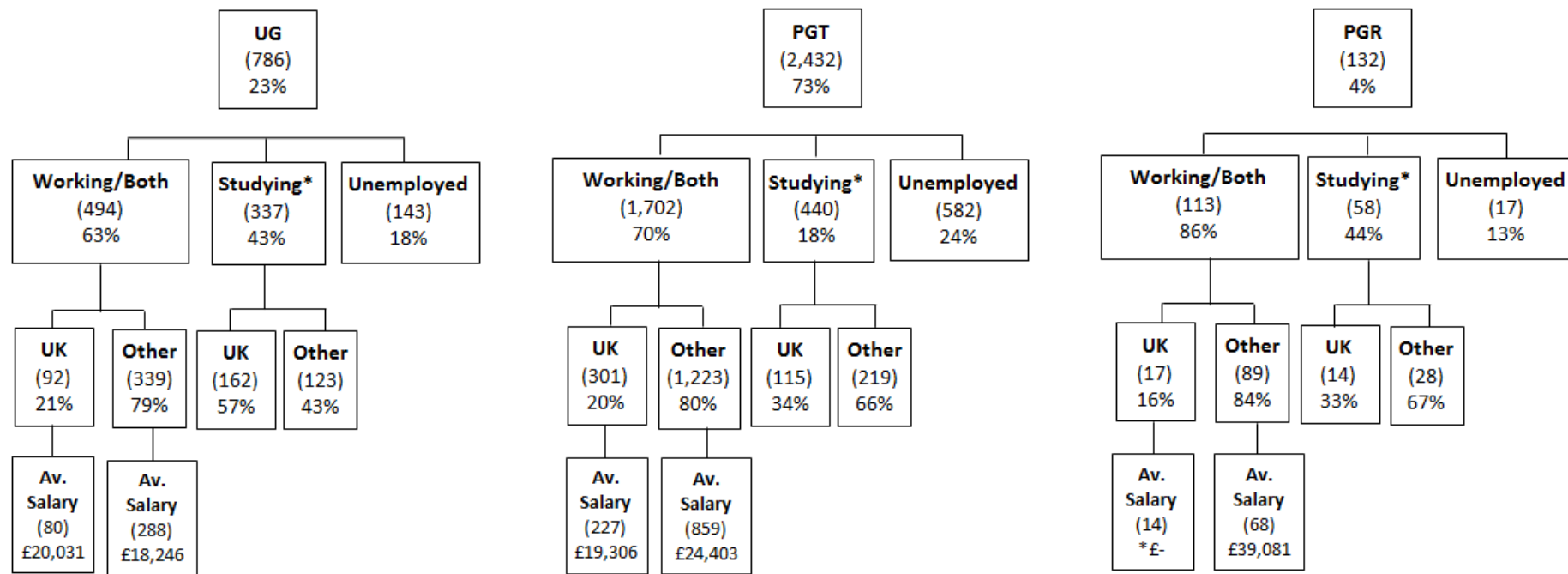

Note: base numbers may add up to more than the total number of respondents as graduates may be studying and working at the same time

*base number too low to report salary

Appendix 10 – Status of graduates, 2½ years after graduation, by study level (2007 cohort)

2½ years after graduation – 1st wave

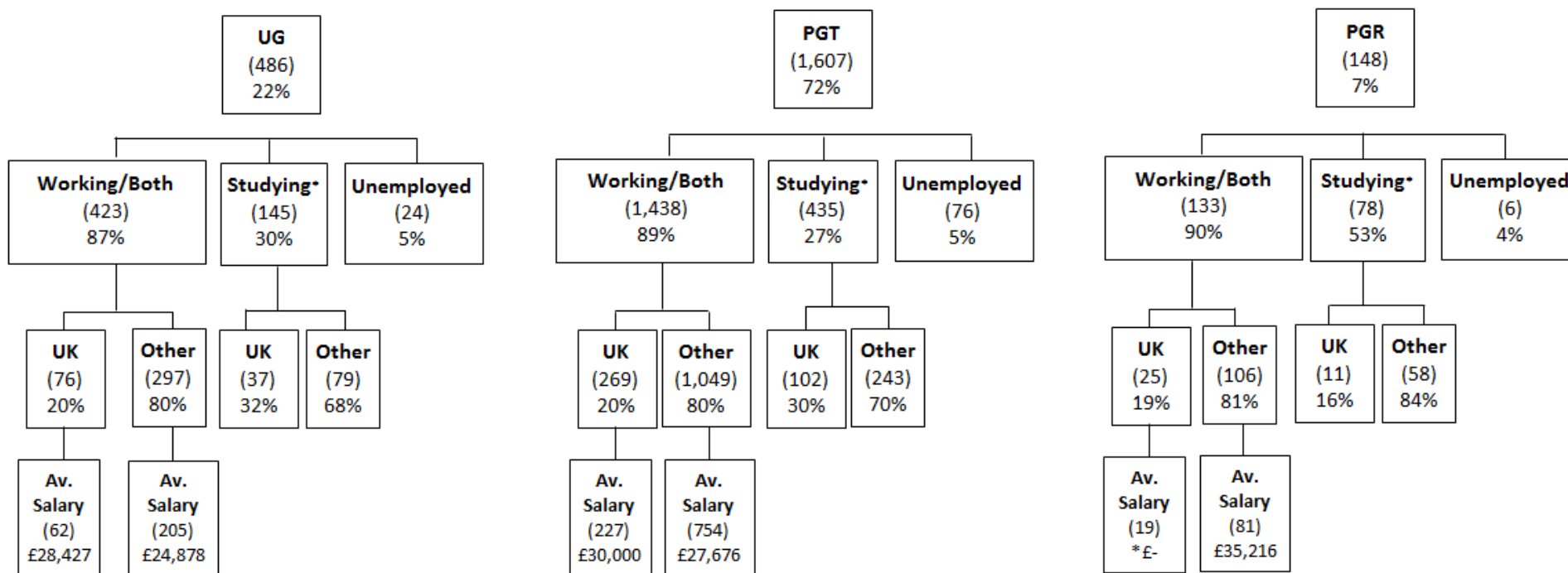

Note: base numbers may add up to more than the total number of respondents as graduates may be studying and working at the same time

Appendix 12 – Status of graduates, 2½ years after graduation, by top 3 nationalities (2008 cohort)

2½ years after graduation – 2nd wave

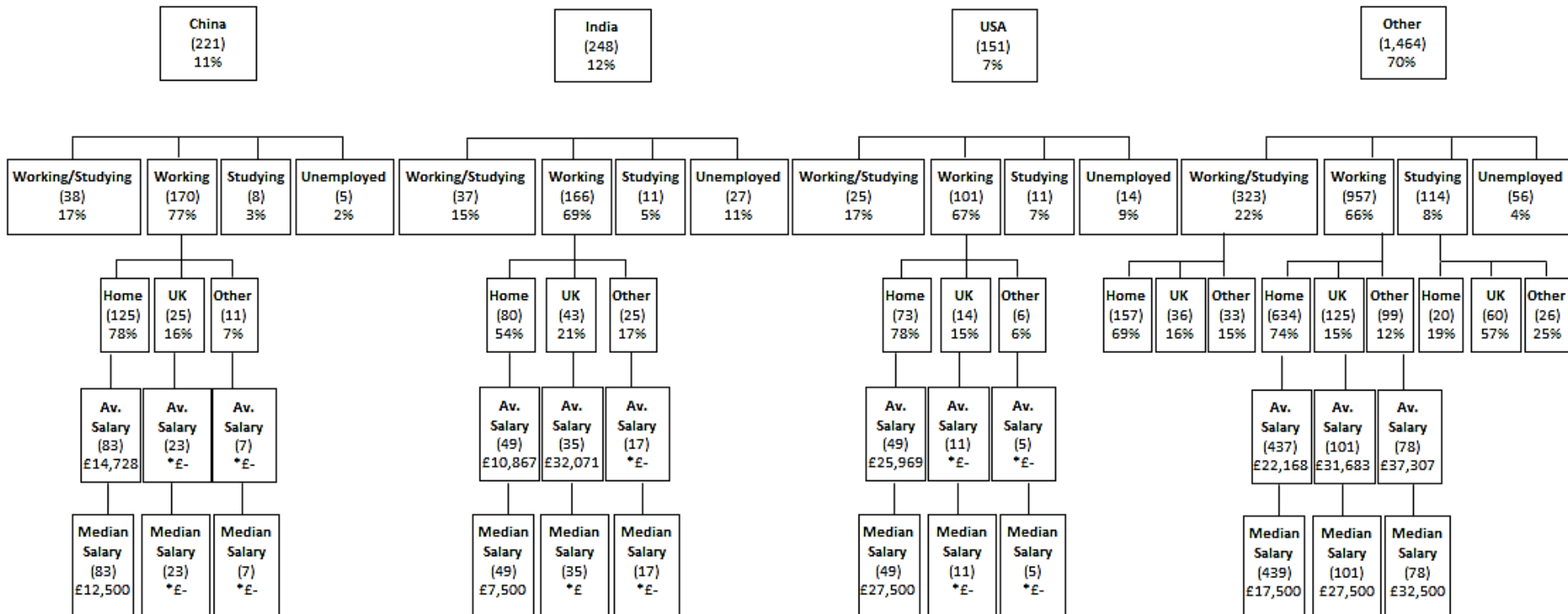

Note: base numbers too low to report location of graduates from USA, India, and China who are studying or working/studying simultaneously

*base numbers too low to report salaries

Crown copyright 2011

You may re-use this information (not including logos) free of charge in any format or medium, under the terms of the Open Government Licence. Visit www.nationalarchives.gov.uk/doc/open-government-licence, write to the Information Policy Team, The National Archives, Kew, London TW9 4DU, or email: psi@nationalarchives.gsi.gov.uk.

This publication is also available on our website at www.bis.gov.uk

Any enquiries regarding this publication should be sent to:

Department for Business, Innovation and Skills
1 Victoria Street
London SW1H 0ET
Tel: 020 7215 5000

If you require this publication in an alternative format, email enquiries@bis.gsi.gov.uk, or call 020 7215 5000.

URN 12/540